

# Exhaust Cleaner for Clean Room

## Series AMP

RoHS

An exhaust cleaner that can be used inside a clean room

**Exhaust air cleanliness: Equivalent to ISO Class 5 (Class 100 Fed.Std.209D)**  
(Consult SMC in advance, as this will differ depending on the operating conditions.)

- **Particles of 0.3 μm or larger are 3.5 particles/L or less**  
Since it is possible to release exhaust air from pneumatic equipment directly into a clean room, piping to exhaust ducts is unnecessary.

**Worry free two stage element construction**

- **After the first element is saturated with oil, the oil flowing into the secondary side is collected by the second element. This prevents discharge to the outside for a fixed time.**



### How to Order

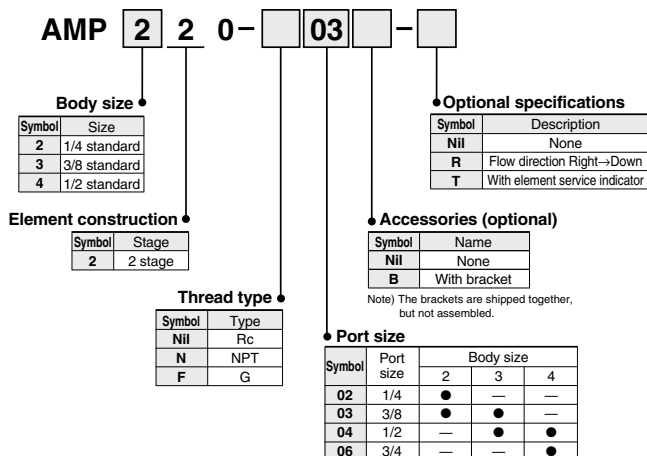

### Models

Model	AMP220	AMP320	AMP420
Maximum flow capacity L/min (ANR)	200	500	1000
Port size (nominal size B)	1/4, 3/8	3/8, 1/2	1/2, 3/4
Weight (kg)	0.43	0.68	1.15

Refer to page 693 for model selection.

### Specifications

Fluid	Compressed air
Element upstream pressure	0.1 MPa or less
Ambient and fluid temperature	5 to 50°C
Filtration degree	0.01 μm (Trapping efficiency 95%)
Downstream cleanliness	Particles of 0.3 μm or larger: 100 particles or less/ft <sup>3</sup> (35 particles or less/10 L (ANR))
Element life	One year from first use (or when upstream pressure reaches 0.1 MPa, even if less than one year from first use)
Element life indication (saturated with oil)	Element color indication (replace if red dots appear on the element surface, even if less than one year from first use)
Element construction	Two stage element
Silencing effect	40 dB (A) or more

Refer to page 694 for specific product precautions.

### Accessories (Optional)

Applicable model	AMP220	AMP320	AMP420
Bracket assembly (with 2 cap bolts with 2 spring washers)	BM66	BM67	BM68

**Construction**

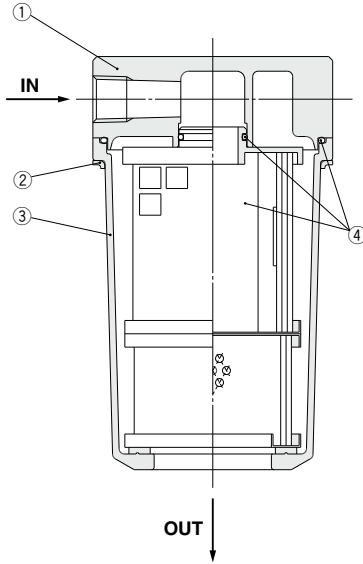

**Parts list**

No.	Description	Material	Note
1	<b>Body</b>	Aluminum alloy	Chromated, Baking finish
2	<b>Ring</b>	Stainless steel	
3	<b>Case</b>	Resin	

**Replacement parts**

No.	Description	Part number			Note
		AMP220	AMP320	AMP420	
4	<b>Element assembly</b>	AMP-EL220	AMP-EL320	AMP-EL420	With O-ring

Note) The first and second elements are integrated, and cannot be replaced separately.

AN  
VCHN  
AMC  
AMV  
AMP

# Series AMP

## Dimensions

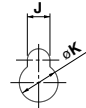
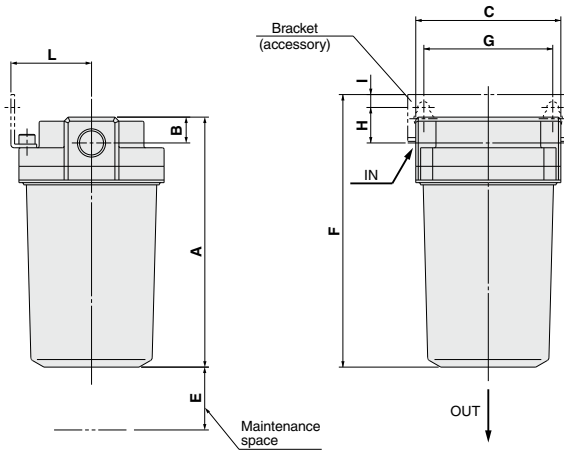
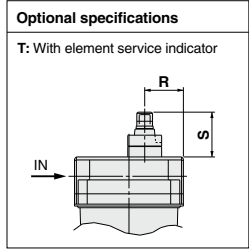
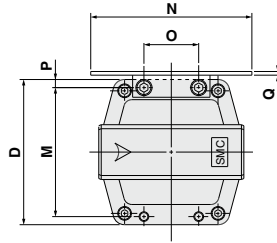

**Bracket mounting hole**

Model	Applicable screw
AMP220	M5 hexagon socket head cap screw
AMP320	M6 hexagon socket head cap screw
AMP420	M8 hexagon socket head cap screw

Model	Port size (nominal size B)	A	B	C	D	E	Bracket related dimensions													Element service indicator related dimensions	
							F	G	H	I	J	K	L	M	N	O	P	Q	R	S	
AMP220	1/4, 3/8	108	13	76	76	80	123	66	20	8	6	10	40	66	84	28	5	2	26	37	
AMP320	3/8, 1/2	155	16	90	90	120	169	80	22	8	7	12	50	80	100	34	5	2.3	32	37	
AMP420	1/2, 3/4	221	19	106	106	180	237	90	25	10	10	15	55	88	110	50	9	3.2	37	37	



# Series AMP Model Selection

## Selection

### ⚠ Caution

1. When selecting an exhaust cleaner, refer to the selection method shown below, as the selection method will differ for exhaust from actuator drive systems, etc., and exhaust from ejectors, etc.

(Take note that an exhaust flow rate exceeding that of the model selected can cause a drop in exhaust air cleanliness, reduced performance of drive equipment and ejectors, etc., and damage to the element.)

### 2. Exhaust from drive systems

1. Find the air flow required for the actuator to be used. When operating with common piping, add up the required air flow for all actuators that will be operated simultaneously and find the maximum air flow.
2. Select a model such that the maximum required air flow obtained in (1) does not exceed the maximum flow rate line of the exhaust cleaner.

### 3. Exhaust from ejectors, etc.

1. In case of ejectors or other equipment whose performance can be affected by back pressure on the exhaust air, confirm the range in which the equipment will not be affected by back pressure.
2. In the case of ejectors, the exhaust flow rate is the total of the maximum suction flow rate and the air consumption. Since the method of calculating the exhaust flow rate differs in this way depending on the equipment, confirm this in the catalog or instruction manual of the equipment to be used.
3. When operating with common piping, add up the exhaust flow rates for all equipment that will be exhausted simultaneously and find the maximum exhaust flow rate.
4. Find the upstream pressure in the flow characteristic graph, using the maximum exhaust flow rate obtained in (3) as the exhaust flow rate. Select a model such that the upstream pressure is lower than the back pressure generated when the exhaust flow rate is at a maximum.

### Flow characteristic graph (Representative value)

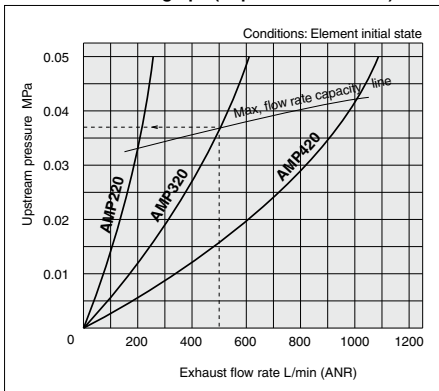

Viewing the graph: When using AMP320 at a flow rate of 500 L/min, the upstream pressure is 0.037MPa.

### ⚠ Caution

4. Exhaust flow speed characteristics are shown in graph 2.

1. Operate giving consideration to the effects of turbulence on dust, etc., that has settled on the floor or other areas.
2. In cases where there is concern about the effect of turbulence on dust, install in a location where dust will not be affected.

### Exhaust flow speed (Representative value)

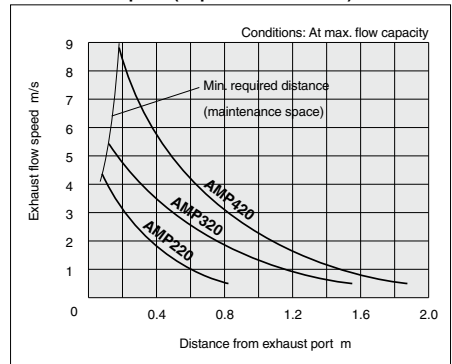

### <Measurement>

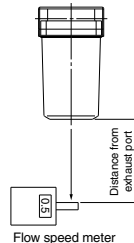

AN  
VCHN  
AMC  
AMV  
AMP



# Series AMP Specific Product Precautions

Be sure to read before handling. Refer to front matter 56 for Safety Instructions and Best Pneumatics No. 5 for Air Cleaning Equipment Precautions.

## Mounting

### Caution

1. Air piping should be thoroughly flushed before mounting.
2. When piping and fittings, etc. are being screwed together, take care that chips from the pipe threads, sealing material and other debris do not get inside the piping.  
Further, when pipe tape is used, leave 1.5 to 2 thread ridges exposed at the end of the threads.
3. Mount the unit vertically. Furthermore, when mounting is performed, the case section (resin) will be damaged if it is held while screwing in piping, etc. Screw in piping while holding the upper body area (die-cast aluminum) with a wrench or other tool.
4. In cases such as common piping, reverse flow may occur depending on the timing for switching of solenoid valves, etc. In this situation, install a check valve on the upstream side.
5. Ensure the necessary space for maintenance and inspections. (Confirm with the dimensions on page 692.)

## Operating Environment

### Warning

1. Do not use in environments or locations where there is a danger of the case or element service indicator (optional specification: T) being penetrated.
2. Since the case material is nylon, avoid use in environments with chemicals such as alcohol, thinner, carbon tetrachloride, chloroform, aniline, cyclohexane, trichloroethylene, sulfuric acid, lactic acid, water soluble cutting oil (alkaline), etc.  
Furthermore, use a neutral detergent for cleaning the case.
3. Do not use in locations where static electric charge will be a problem.
4. Block off heat from nearby heat sources.

If heat sources are located nearby, the temperature of the product may rise above the operating temperature range due to radiated heat. Block off this heat with a cover, etc.

## Supply Air

### Caution

1. The product cannot be used with air containing water droplets.
2. Install a mist separator (series AM), micro mist separator (series AMD), or micro mist separator with pre-filter (series AMH) on the air supply side.
3. When using ejectors, etc., do not allow liquids such as water or oil to be drawn in with the air.

## Maintenance

### Caution

1. Replace the element after one year of use, or when the upstream pressure reaches 0.1MPa even if one year has not elapsed.

If operation is continued without replacing the element, the cleanliness of the exhaust air will decline.

When replacing the element, also install a new O-ring.

(When equipped with an element service indicator (optional specification: T), the condition of the element can be easily confirmed.)

2. When saturated with oil, red dots appear on the surface of the first element. Check it once a day and replace it immediately with a new element when red dots appear.

If operation is continued after red dots have appeared, the second element will also be saturated with oil, and oil mist imbued with red dye will be mixed with the exhaust air, contaminating the surrounding air.

## Operation in a Clean Room

### Caution

1. Open the inner bag of the double packaging in a clean room or other clean environment.
2. In a down flow area, mount with the exhaust port facing downward.
3. Avoid mounting in locations where exhaust air will blow directly on work pieces, etc.
4. Confirm the exhaust flow speed, and operate giving consideration to the effect of turbulence on dust, etc., in a clean room.