

Compact Guide Cylinder Series MGP

ø12, ø16, ø20, ø25, ø32, ø40, ø50, ø63, ø80, ø100

How to Order

Compact Guide Cylinder **MGP** **M** **25** **30** **M9BW**

Compact Guide Cylinder

Bearing type

M	Slide bearing
L	Ball bushing bearing

Bore size

12	12 mm	40	40 mm
16	16 mm	50	50 mm
20	20 mm	63	63 mm
25	25 mm	80	80 mm
32	32 mm	100	100 mm

Thread type

Nil	M5 x 0.8
	Rc
N	NPT
TF	G

* For bore sizes 12 and 16, only M5 x 0.8 is available.

Number of auto switches

Nil	2 pcs.
S	1 pc.
n	n pcs.

Auto switch

Nil	Without auto switch (Built-in magnet)
------------	---------------------------------------

* For the applicable auto switch model, refer to the table below.

Cylinder stroke (mm)
Refer to "Standard Stroke" on page 273.

Made to Order Specification
For details, refer to page 273.

Applicable Auto Switch/Refer to pages 1719 to 1827 for further information on auto switches.

Type	Special function	Electrical entry	Indicator light	Wiring (Output)	Load voltage		Auto switch model		Lead wire length (m)				Pre-wired connector	Applicable load		
					DC	AC	Perpendicular	In-line	0.5 (Nil)	1 (M)	3 (L)	5 (Z)				
Solid state switch	—	Grommet	Yes	3-wire (NPN)	24V	5V, 12V	—	M9NV	M9N	●	●	●	○	○	Relay, PLC	IC circuit
				3-wire (PNP)				M9PV	M9P	●	●	●	○	○		
				2-wire	12V	M9BV	M9B	●	●	●	○	○	—			
				3-wire (NPN)	24V	5V, 12V	—	M9NWV	M9NW	●	●	●		○		○
	3-wire (PNP)			M9PWV				M9PW	●	●	●	○	○	—		
	Diagnostic indication (2-color indication)			2-wire	12V	M9BWV	M9BW	●	●	●	○	○	—			
				3-wire (NPN)	24V	5V, 12V	—	M9NAV	M9NA	○	○	●		○		○
	Water resistant (2-color indication)			3-wire (PNP)				M9PAV	M9PA	○	○	●	○	○		○
				2-wire	12V	M9BAV	M9BA	○	○	●	○	○	—			
	Magnetic field resistant (2-color indication)			2-wire (Non-polar)	—	—	—	P3DW**	○	—	●	●		○		—
—		—	P4DW	—	—	●	—	●	●	○						
Reed switch	—	Grommet	Yes	3-wire (NPN equivalent)	—	5V	—	A96V	A96	●	—	●	—	—	IC circuit	—
				2-wire	24V	12V	100V	A93V	A93	●	—	●	—	—	—	Relay, PLC
							100V or less	A90V	A90	●	—	●	—	—	—	IC circuit

* Lead wire length symbols: 0.5 m..... Nil (Example) M9NW
 1 m..... M (Example) M9NWM
 3 m..... L (Example) M9NWL
 5 m..... Z (Example) M9NWZ

* Solid state auto switches marked with "○" are produced upon receipt of order.
 * Bore sizes 32 to 100 are available for D-P4DW.
 ** Bore sizes 25 to 100 are available for D-P3DW.

* Since there are other applicable auto switches than listed, refer to page 336 for details.
 * For details about auto switches with pre-wired connector, refer to pages 1784 and 1785. For D-P3DW□, refer to pages 1773-1 and 1773-2.
 * Auto switches are shipped together (not assembled).

Specifications



Bore size	ø12	ø16	ø20	ø25	ø32	ø40	ø50	ø63	ø80	ø100
Action	Double acting									
Fluid	Air									
Proof pressure	1.5 MPa									
Maximum operating pressure	1.0 MPa									
Minimum operating pressure	0.12 MPa		0.1 MPa							
Ambient and fluid temperature	-10 to 60°C (No freezing)									
Piston speed ^(Note)	50 to 500 mm/s								50 to 400 mm/s	
Cushion	Rubber bumper on both ends									
Lubrication	Not required (Non-lube)									
Stroke length tolerance	+1.5 0 mm									

Note) Maximum speed with no load.

Make a model selection, considering a load according to the graph on pages 275 to 281.

Standard Stroke

Bore size (mm)	Standard stroke (mm)
12, 16	10, 20, 30, 40, 50, 75, 100, 125, 150, 175, 200, 250
20, 25	20, 30, 40, 50, 75, 100, 125, 150, 175, 200, 250, 300, 350, 400
32 to 100	25, 50, 75, 100, 125, 150, 175, 200, 250, 300, 350, 400

Manufacture of Intermediate Stroke



Made to Order Specification
(For details, refer to pages 1829 to 2021.)

Symbol	Specifications
-XA□	Change of guide rod end shape
-XB6	Heat resistant cylinder (-10 to 150°C)
-XB10	Intermediate stroke (Using exclusive body)
-XB13	Low speed cylinder (5 to 50 mm/s)
-XB22	Shock absorber soft type Series RJ type
-XC4	With heavy duty scraper
-XC6	Made of stainless steel
-XC8	Adjustable stroke cylinder/Adjustable extension type
-XC9	Adjustable stroke cylinder/Adjustable retraction type
-XC22	Fluororubber seals
-XC35	With coil scraper
-XC69	With shock absorber
-XC79	Machining tapped hole, drilled hole and pin hole additionally.
-XC82	Bottom mounting style
-X144	Symmetrical port position
-X867	Lateral piping type (Change of plug position)

Description	Spacer installation type		Exclusive body (-XB10)		
	Spacers are installed in the standard stroke cylinder. • ø12 to 32: Available by the 1 mm stroke interval. • ø40 to 100: Available by the 5 mm stroke interval.		Dealing with the stroke by making an exclusive body. • All bore sizes are available by the 1 mm interval.		
Part no.	Refer to "How to Order" for the standard model numbers.			Suffix "-XB10" to the end of standard part number. ^(Note)	
Applicable stroke (mm)	ø12, ø16	1 to 249		ø12, ø16	11 to 249
	ø20, ø25, ø32	1 to 399		ø20, ø25	21 to 399
	ø40 to ø100	5 to 395		ø32 to ø100	26 to 399
Example	Part no.: MGPM20-39 A spacer 1 mm in width is installed in a MGPM20-40. C dimension is 77 mm.			Part no.: MGPM20-39-XB10 Special body manufactured for 39 stroke. C dimension is 76 mm.	

Theoretical Output

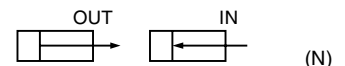

Bore size (mm)	Rod size (mm)	Operating direction	Piston area (mm ²)	Operating pressure (MPa)								
				0.2	0.3	0.4	0.5	0.6	0.7	0.8	0.9	1.0
12	6	OUT	113	23	34	45	57	68	79	90	102	113
		IN	85	17	26	34	43	51	60	68	77	85
16	8	OUT	201	40	60	80	101	121	141	161	181	201
		IN	151	30	45	60	76	91	106	121	136	151
20	10	OUT	314	63	94	126	157	188	220	251	283	314
		IN	236	47	71	94	118	142	165	189	212	236
25	12	OUT	491	98	147	196	246	295	344	393	442	491
		IN	378	76	113	151	189	227	265	302	340	378
32	16	OUT	804	161	241	322	402	482	563	643	724	804
		IN	603	121	181	241	302	362	422	482	543	603
40	16	OUT	1257	251	377	503	629	754	880	1006	1131	1257
		IN	1056	211	317	422	528	634	739	845	950	1056
50	20	OUT	1963	393	589	785	982	1178	1374	1570	1767	1963
		IN	1649	330	495	660	825	990	1154	1319	1484	1649
63	20	OUT	3117	623	935	1247	1559	1870	2182	2494	2805	3117
		IN	2803	561	841	1121	1402	1682	1962	2242	2523	2803
80	25	OUT	5027	1005	1508	2011	2514	3016	3519	4022	4524	5027
		IN	4536	907	1361	1814	2268	2722	3175	3629	4082	4536
100	30	OUT	7854	1571	2356	3142	3927	4712	5498	6283	7069	7854
		IN	7147	1429	2144	2859	3574	4288	5003	5718	6432	7147

Note) Theoretical output (N) = Pressure (MPa) x Piston area (mm²)

Series MGP

Mass

Slide Bearing: MGPM12 to 100

(kg)

Bore size (mm)	Model	Standard stroke (mm)															
		10	20	25	30	40	50	75	100	125	150	175	200	250	300	350	400
12	MGPM12	0.24	0.28	—	0.31	0.35	0.39	0.50	0.59	0.70	0.79	0.89	0.98	1.17	—	—	—
16	MGPM16	0.33	0.38	—	0.43	0.48	0.53	0.68	0.80	0.97	1.09	1.22	1.35	1.60	—	—	—
20	MGPM20	—	0.67	—	0.75	0.83	0.91	1.17	1.37	1.57	1.76	1.96	2.16	2.63	3.03	3.42	3.82
25	MGPM25	—	0.95	—	1.05	1.16	1.27	1.65	1.92	2.19	2.47	2.74	3.01	3.67	4.21	4.76	5.30
32	MGPM32	—	—	1.69	—	—	2.07	2.47	2.85	3.24	3.62	4.00	4.38	5.33	6.09	6.86	7.62
40	MGPM40	—	—	1.95	—	—	2.37	2.83	3.25	3.68	4.10	4.53	4.95	5.99	6.85	7.70	8.55
50	MGPM50	—	—	3.36	—	—	4.00	4.73	5.37	6.01	6.65	7.29	7.93	9.54	10.8	12.1	13.4
63	MGPM63	—	—	4.18	—	—	4.94	5.78	6.54	7.29	8.05	8.80	9.56	11.4	12.9	14.4	15.9
80	MGPM80	—	—	6.49	—	—	7.43	8.67	9.61	10.5	11.5	12.4	13.4	15.8	17.7	19.5	21.4
100	MGPM100	—	—	10.5	—	—	11.9	13.6	14.9	16.3	17.6	18.9	20.2	23.6	26.2	28.9	31.5

Ball Bushing Bearing: MGPL12 to 100

(kg)

Bore size (mm)	Model	Standard stroke (mm)															
		10	20	25	30	40	50	75	100	125	150	175	200	250	300	350	400
12	MGPL12	0.24	0.27	—	0.30	0.35	0.39	0.47	0.56	0.66	0.74	0.83	0.91	1.08	—	—	—
16	MGPL16	0.34	0.39	—	0.43	0.51	0.56	0.67	0.79	0.93	1.04	1.16	1.28	1.50	—	—	—
20	MGPL20	—	0.70	—	0.77	0.89	0.97	1.14	1.31	1.52	1.69	1.87	2.04	2.42	2.77	3.12	3.47
25	MGPL25	—	0.98	—	1.07	1.25	1.34	1.57	1.81	2.08	2.31	2.54	2.77	3.27	3.74	4.20	4.66
32	MGPL32	—	—	1.54	—	—	1.85	2.30	2.62	2.99	3.31	3.62	3.94	4.63	5.26	5.89	6.52
40	MGPL40	—	—	1.79	—	—	2.15	2.64	3.00	3.42	3.78	4.14	4.50	5.28	6.00	6.72	7.44
50	MGPL50	—	—	3.11	—	—	3.66	4.41	4.96	5.60	6.15	6.70	7.25	8.48	9.57	10.7	11.8
63	MGPL63	—	—	3.93	—	—	4.59	5.46	6.12	6.88	7.54	8.21	8.87	10.3	11.7	13.0	14.3
80	MGPL80	—	—	6.25	—	—	7.39	8.69	9.51	10.3	11.1	12.0	12.8	14.7	16.3	18.0	19.6
100	MGPL100	—	—	9.89	—	—	11.6	13.4	14.5	15.7	16.9	18.1	19.3	21.9	24.2	26.6	28.9

Allowable Rotational Torque of Plate

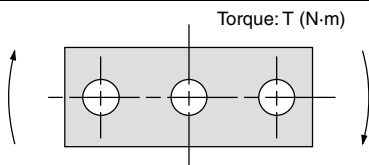

Non-rotating Accuracy of Plate

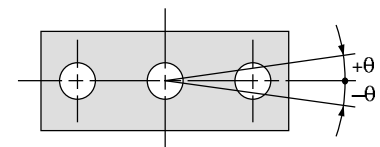

For non-rotating accuracy without load, use a value no more than the values in the table as a guide.

Bore size (mm)	Bearing type	Stroke (mm)															
		10	20	25	30	40	50	75	100	125	150	175	200	250	300	350	400
12	MGPM	0.39	0.32	—	0.27	0.24	0.21	0.43	0.36	0.31	0.27	0.24	0.22	0.19	—	—	—
	MGPL	0.61	0.45	—	0.35	0.58	0.50	0.37	0.29	0.24	0.20	0.18	0.16	0.12	—	—	—
16	MGPM	0.69	0.58	—	0.49	0.43	0.38	0.69	0.58	0.50	0.44	0.40	0.36	0.30	—	—	—
	MGPL	0.99	0.74	—	0.59	0.99	0.86	0.65	0.52	0.43	0.37	0.32	0.28	0.23	—	—	—
20	MGPM	—	1.05	—	0.93	0.83	0.75	1.88	1.63	1.44	1.28	1.16	1.06	0.90	0.78	0.69	0.62
	MGPL	—	1.26	—	1.03	2.17	1.94	1.52	1.25	1.34	1.17	1.03	0.93	0.76	0.65	0.56	0.49
25	MGPM	—	1.76	—	1.55	1.38	1.25	2.96	2.57	2.26	2.02	1.83	1.67	1.42	1.24	1.09	0.98
	MGPL	—	2.11	—	1.75	3.37	3.02	2.38	1.97	2.05	1.78	1.58	1.41	1.16	0.98	0.85	0.74
32	MGPM	—	—	6.35	—	—	5.13	5.69	4.97	4.42	3.98	3.61	3.31	2.84	2.48	2.20	1.98
	MGPL	—	—	5.95	—	—	4.89	5.11	4.51	6.34	5.79	5.33	4.93	4.29	3.78	3.38	3.04
40	MGPM	—	—	7.00	—	—	5.66	6.27	5.48	4.87	4.38	3.98	3.65	3.13	2.74	2.43	2.19
	MGPL	—	—	6.55	—	—	5.39	5.62	4.96	6.98	6.38	5.87	5.43	4.72	4.16	3.71	3.35
50	MGPM	—	—	13.0	—	—	10.8	12.0	10.6	9.50	8.60	7.86	7.24	6.24	5.49	4.90	4.43
	MGPL	—	—	9.17	—	—	7.62	9.83	8.74	11.6	10.7	9.83	9.12	7.95	7.02	6.26	5.63
63	MGPM	—	—	14.7	—	—	12.1	13.5	11.9	10.7	9.69	8.86	8.16	7.04	6.19	5.52	4.99
	MGPL	—	—	10.2	—	—	8.48	11.0	9.74	13.0	11.9	11.0	10.2	8.84	7.80	6.94	6.24
80	MGPM	—	—	21.9	—	—	18.6	22.9	20.5	18.6	17.0	15.6	14.5	12.6	11.2	10.0	9.11
	MGPL	—	—	15.1	—	—	23.3	22.7	20.6	18.9	17.3	16.0	14.8	12.9	11.3	10.0	8.94
100	MGPM	—	—	38.8	—	—	33.5	37.5	33.8	30.9	28.4	26.2	24.4	21.4	19.1	17.2	15.7
	MGPL	—	—	27.1	—	—	30.6	37.9	34.6	31.8	29.3	27.2	25.3	22.1	19.5	17.3	15.5

Bore size (mm)	Non-rotating accuracy θ	
	MGPM	MGPL
12		
16	$\pm 0.08^\circ$	$\pm 0.10^\circ$
20		
25	$\pm 0.07^\circ$	$\pm 0.09^\circ$
32		
40	$\pm 0.06^\circ$	$\pm 0.08^\circ$
50		
63	$\pm 0.05^\circ$	$\pm 0.06^\circ$
80		
100	$\pm 0.04^\circ$	$\pm 0.05^\circ$

Series MGP Model Selection

Selection Conditions

Mounting orientation	Vertical		Horizontal	
Maximum speed (mm/s)	200 or less	400	200 or less	400
Graph (Slide bearing type)	(1), (2)	(3), (4)	(13), (14)	(15), (16)
Graph (Ball bushing bearing type)	(5) to (8)	(9) to (12)	(17), (18)	(19), (20)

Selection Example 1 (Vertical Mounting)

Selection conditions

Mounting: Vertical
 Bearing type: Ball bushing
 Stroke: 30 stroke
 Maximum speed: 200 mm/s
 Load mass: 3 kg
 Eccentric distance: 90 mm

Find the point of intersection for the load mass of 3 kg and the eccentric distance of 90 mm on graph (5), based on vertical mounting, ball bushing, 30 stroke, and the speed of 200 mm/s.

→MGPL25-30 is selected.

(5) Less than 40 stroke, V = 200 mm/s or less

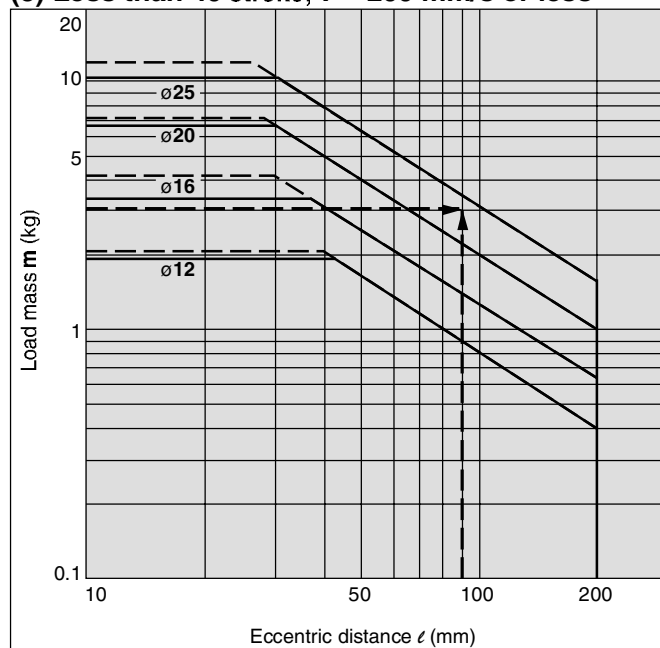

Selection Example 2 (Horizontal Mounting)

Selection conditions

Mounting: Horizontal
 Bearing type: Slide bearing
 Distance between plate and load center of gravity: 50 mm
 Maximum speed: 200 mm/s
 Load mass: 2 kg
 Stroke: 30 stroke

Find the point of intersection for the load mass of 2 kg and 30 stroke on graph (13), based on horizontal mounting, slide bearing, the distance of 50 mm between the plate and load center of gravity, and the speed of 200 mm/s.

→MGPM20-30 is selected.

(13) $l = 50$ mm, V = 200 mm/s or less

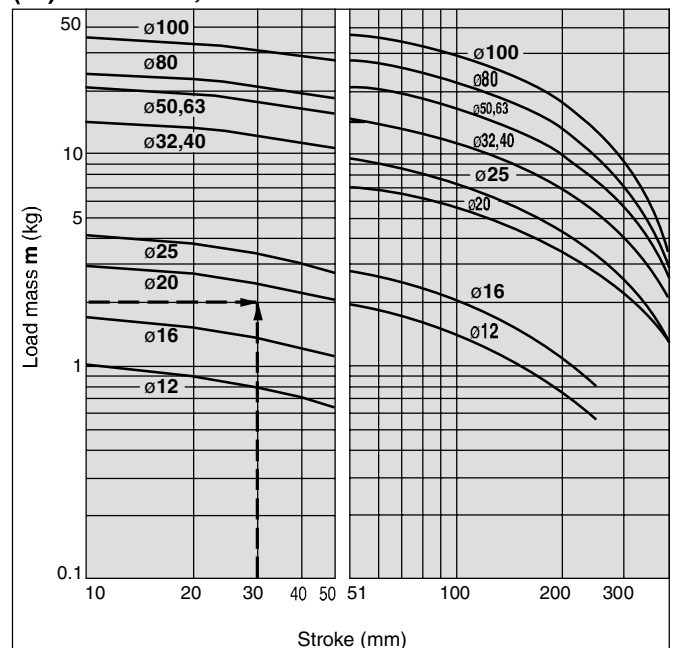

When the maximum speed exceeds 200 mm/s, the allowable load mass is determined by multiplying the value shown in the graph at 400 mm/s by the coefficient listed in the table below.

Maximum	Up to 300 mm/s	Up to 400 mm/s	Up to 500 mm/s
Coefficient	1.7	1	0.6

Series MGP

Vertical Mounting (Slide Bearing)

— Operating pressure 0.4 MPa
 - - - Operating pressure 0.5 MPa or more

MGPM12 to 100

(1) 50 Stroke or Less, V = 200 mm/s or less

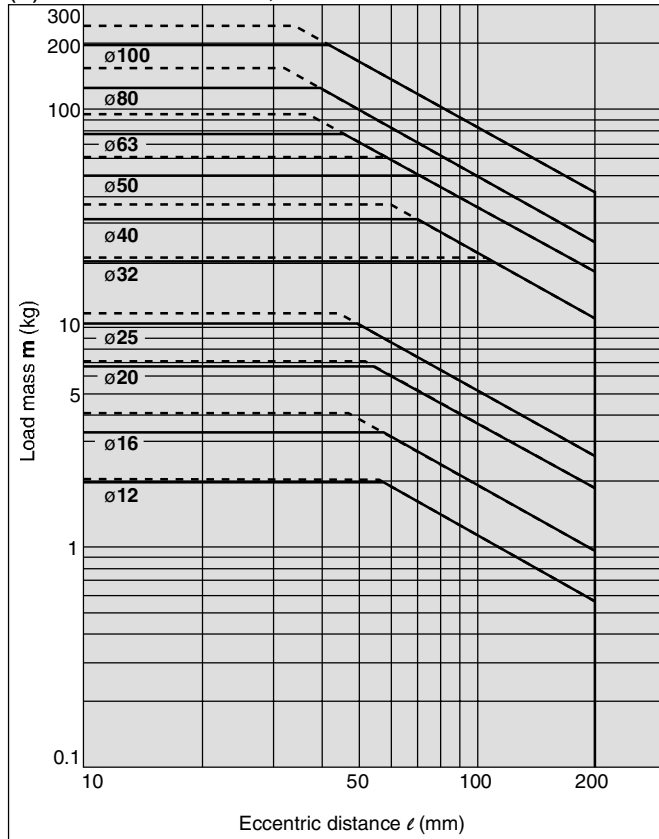

(2) Over 50 Stroke, V = 200 mm/s or less

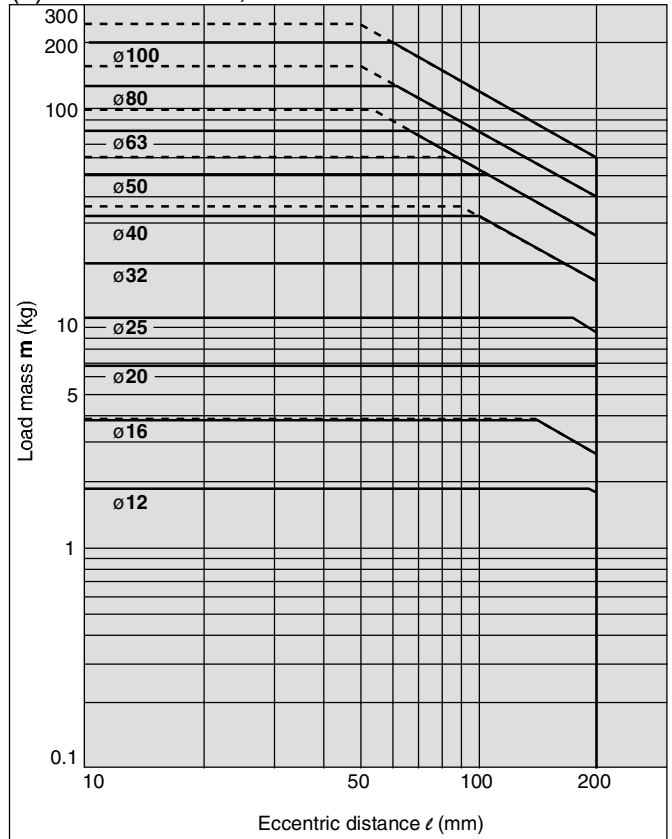

(3) 50 Stroke or Less, V = 400 mm/s

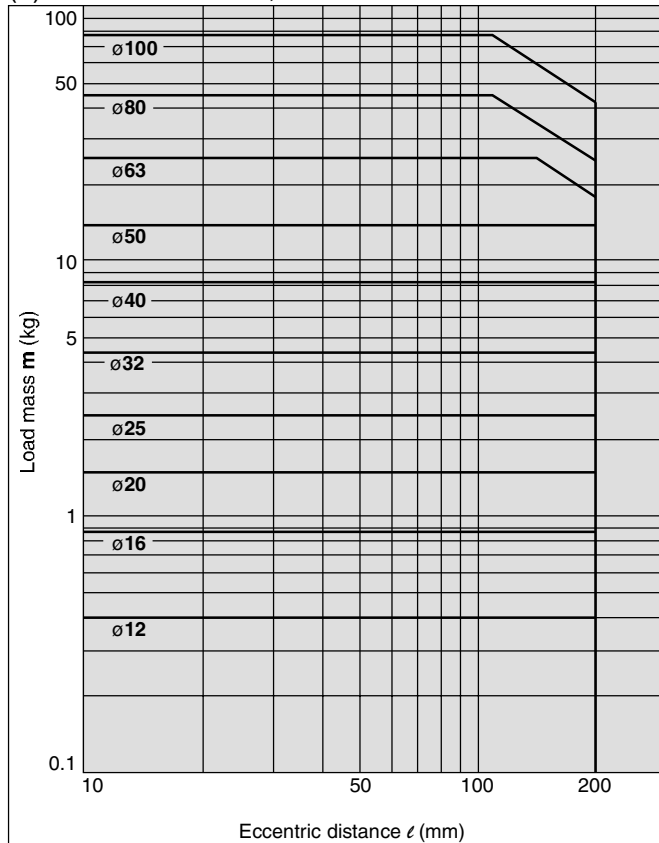

(4) Over 50 Stroke, V = 400 mm/s

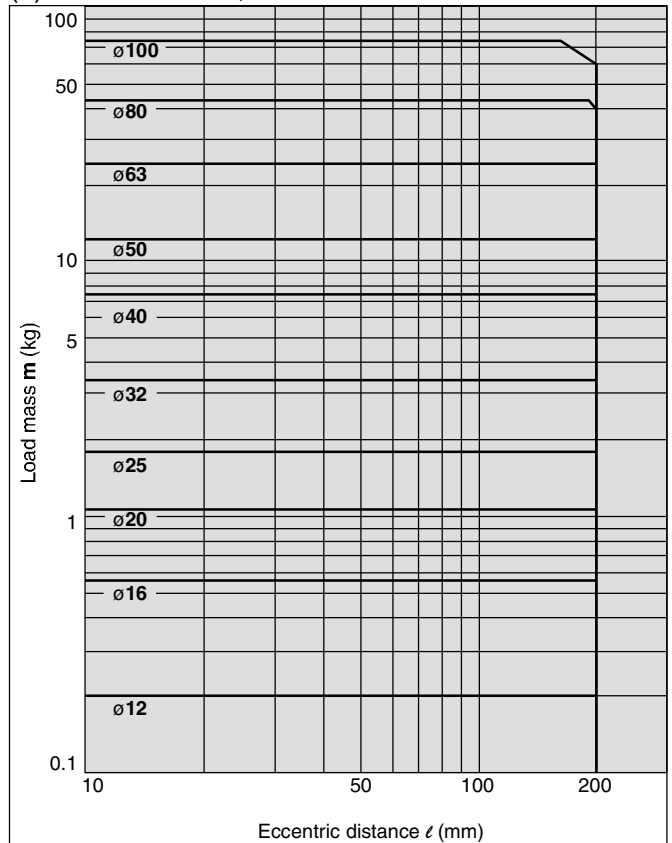

Vertical Mounting (Ball Bushing)

— Operating pressure 0.4 MPa
 - - - - - Operating pressure 0.5 MPa or more

MGPL12 to 25

(5) 30 Stroke or Less, V = 200 mm/s or less

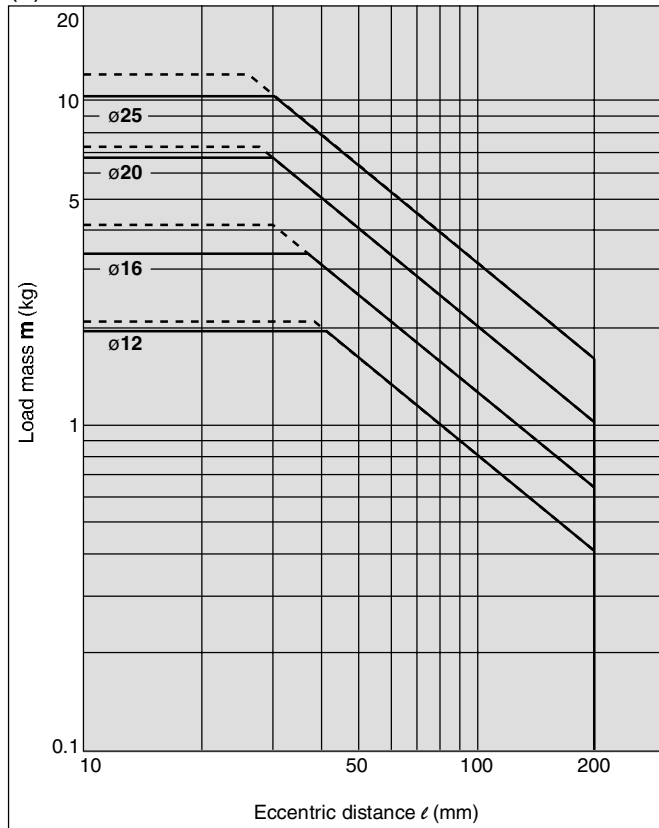

(6) Over 30 Stroke, V = 200 mm/s or less

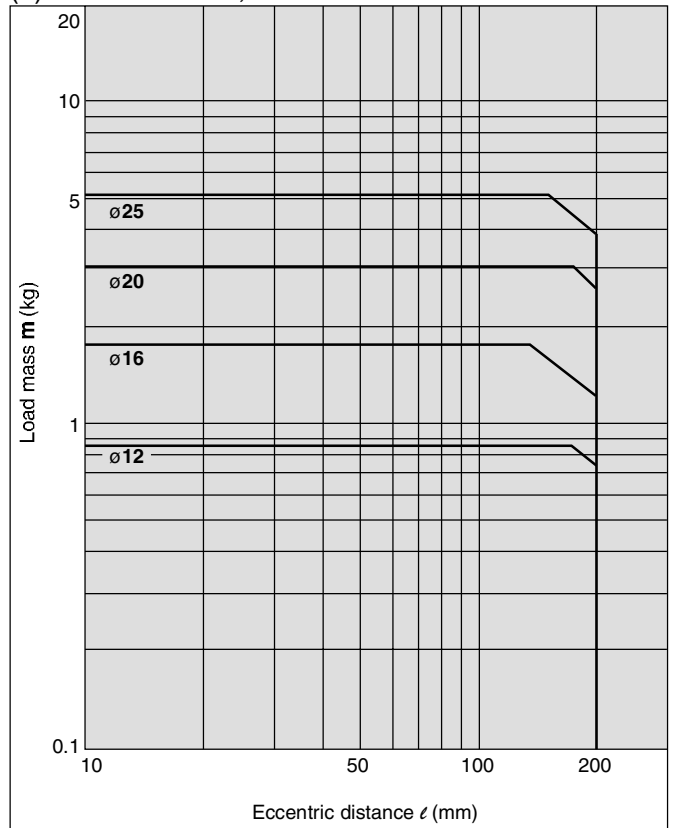

MGPL32 to 100

(7) 50 Stroke or Less, V = 200 mm/s or less

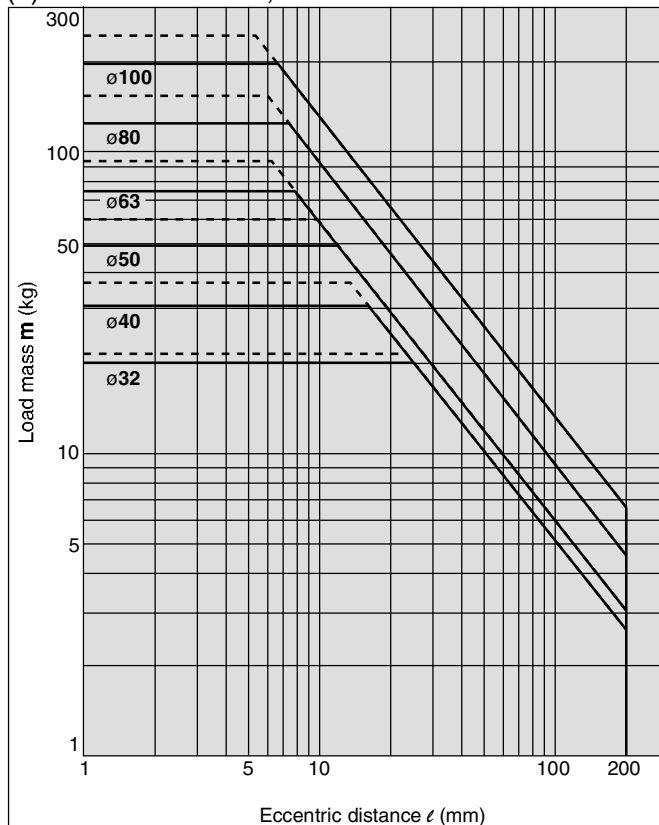

(8) Over 50 Stroke, V = 200 mm/s or less

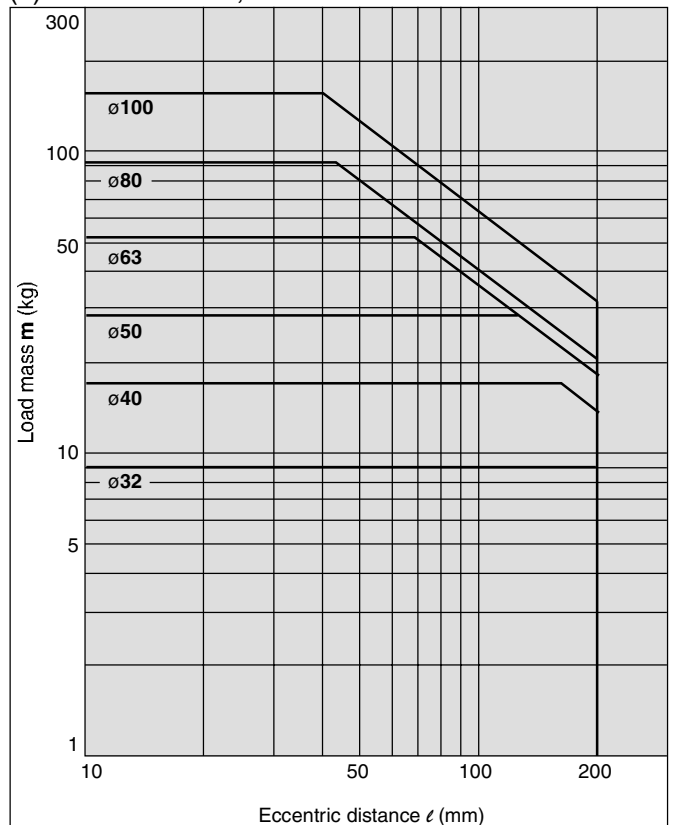

Series MGP

Vertical Mounting (Ball Bushing)

— Operating pressure 0.4 MPa

MGPL12 to 25

(9) 30 Stroke or Less, V = 400 mm/s

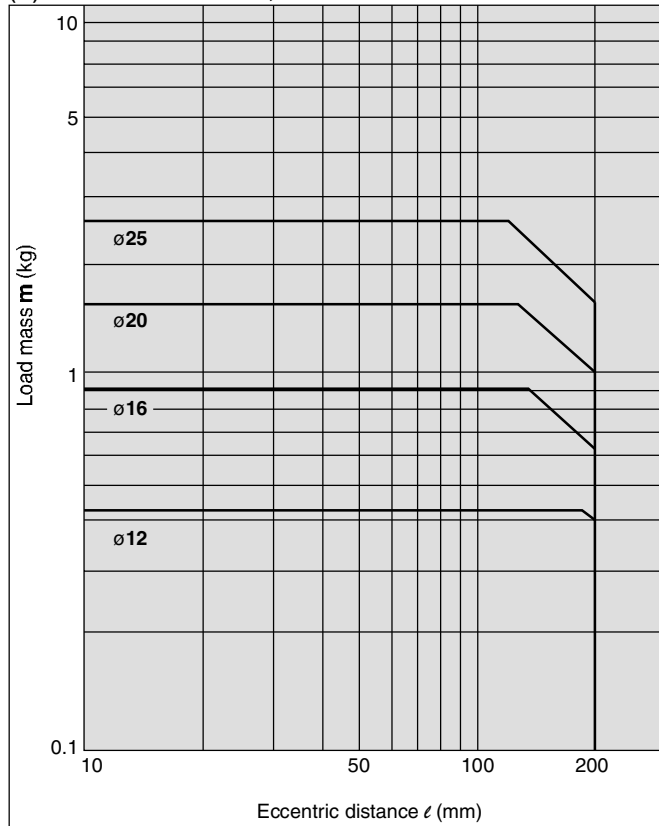

(10) Over 30 Stroke, V = 400 mm/s

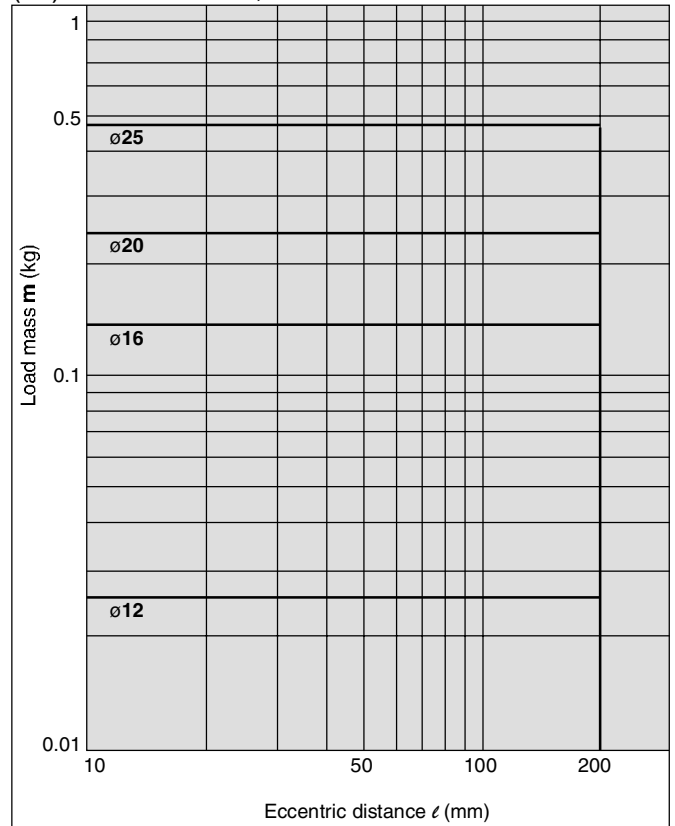

MGPL32 to 100

(11) 50 Stroke or Less, V = 400 mm/s

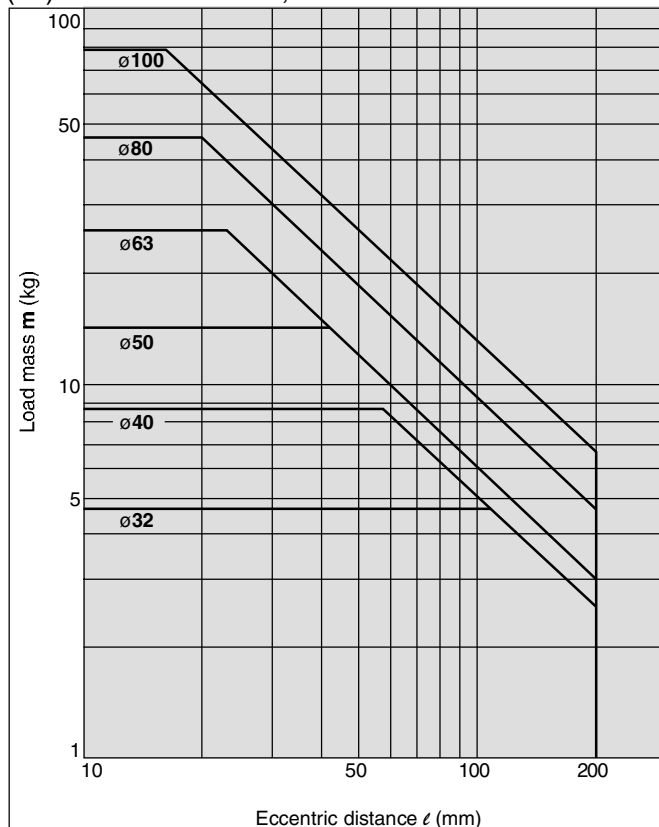

(12) Over 50 Stroke, V = 400 mm/s

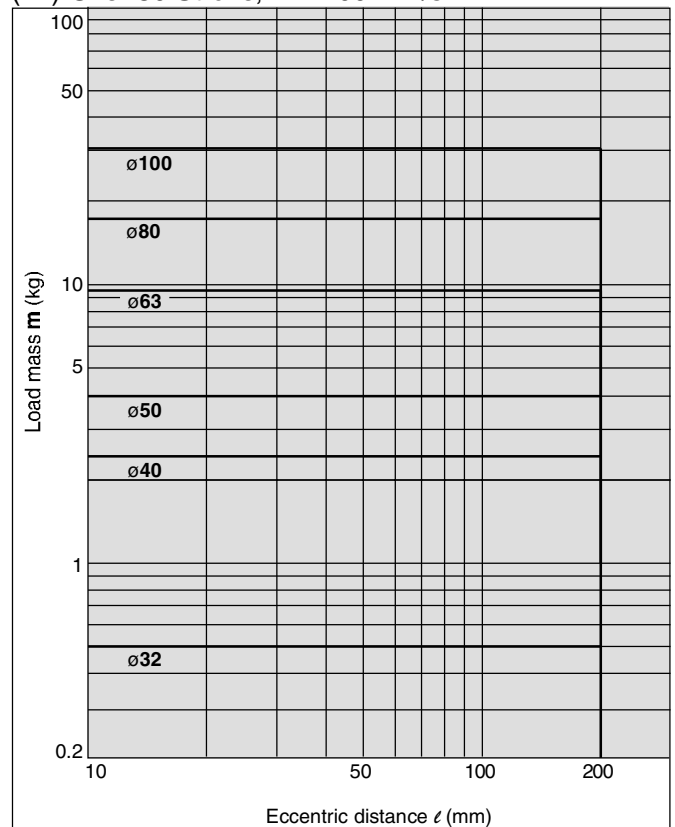

Horizontal Mounting (Slide Bearing)

MGPM12 to 100

(13) $\ell = 50$ mm, $V = 200$ mm/s or less

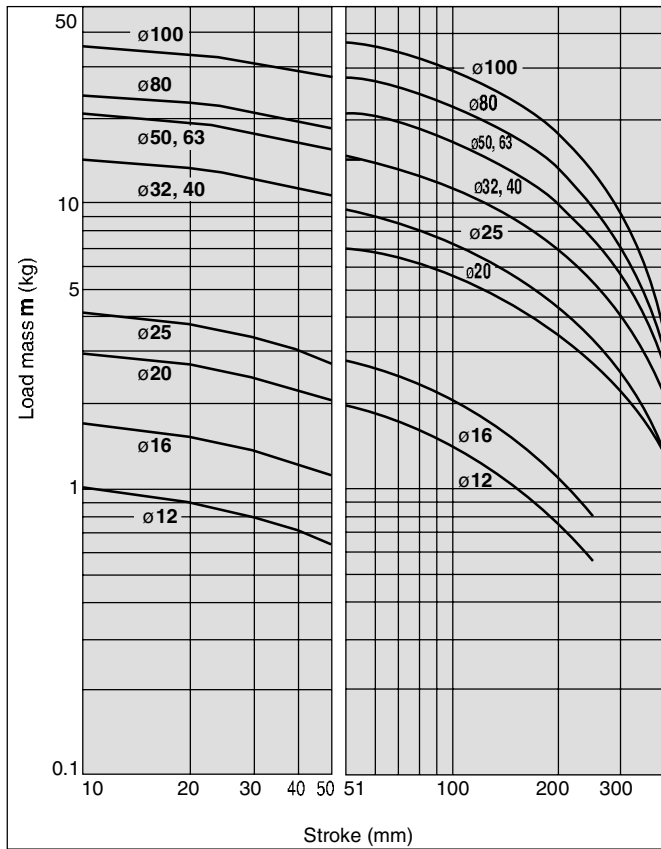

(14) $\ell = 100$ mm, $V = 200$ mm/s or less

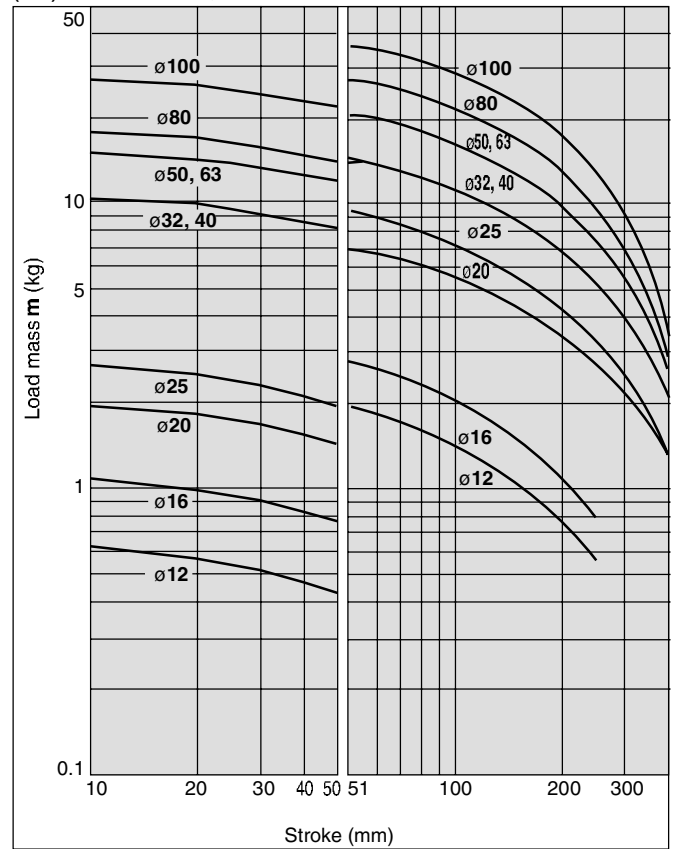

(15) $\ell = 50$ mm, $V = 400$ mm/s

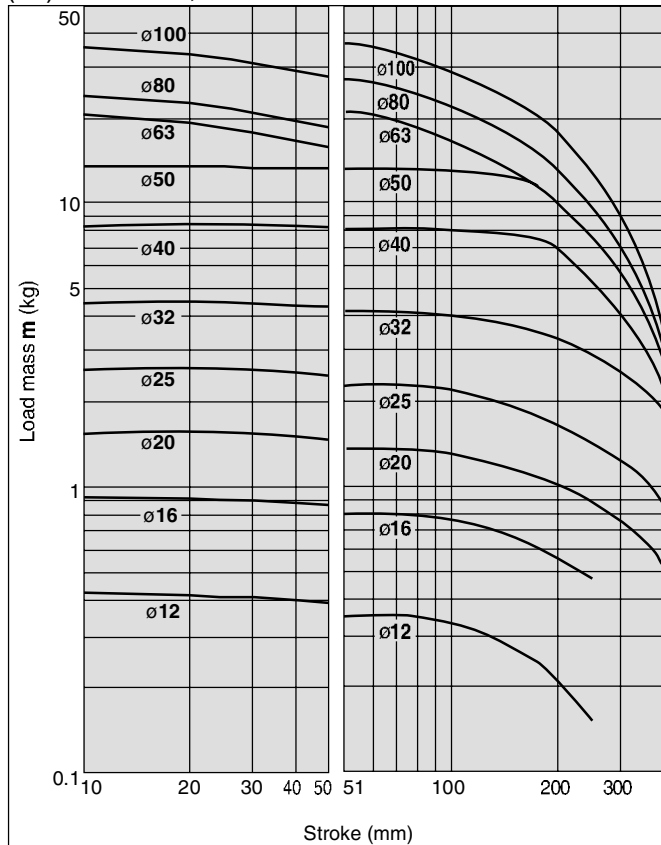

(16) $\ell = 100$ mm, $V = 400$ mm/s

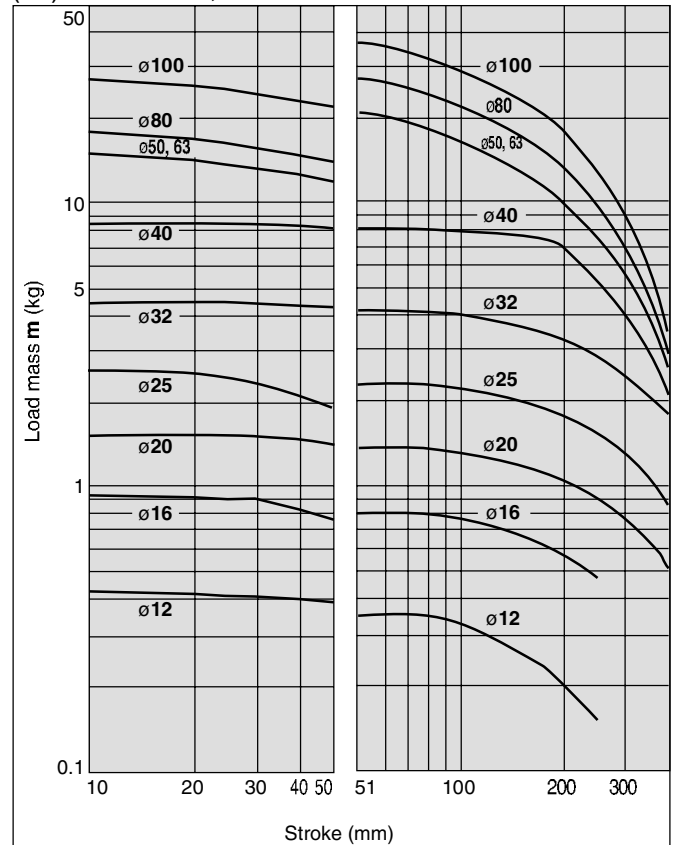

Series MGP

Horizontal Mounting (Ball Bushing)

(17) $\ell = 50$ mm, $V = 200$ mm/s or less

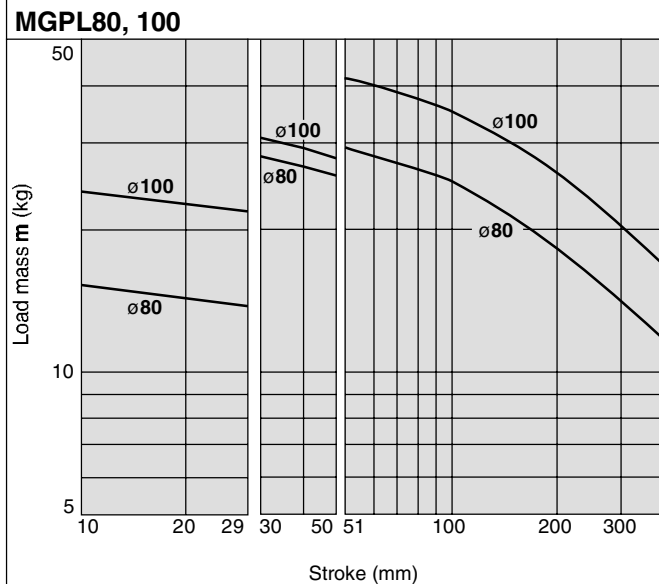
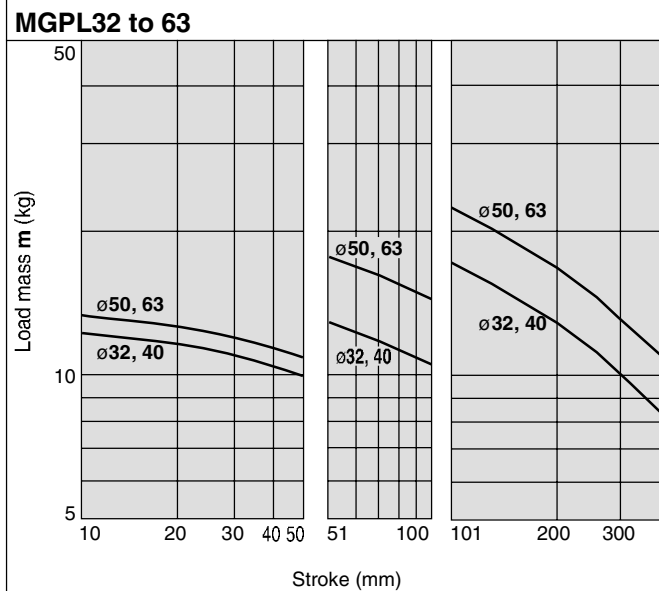
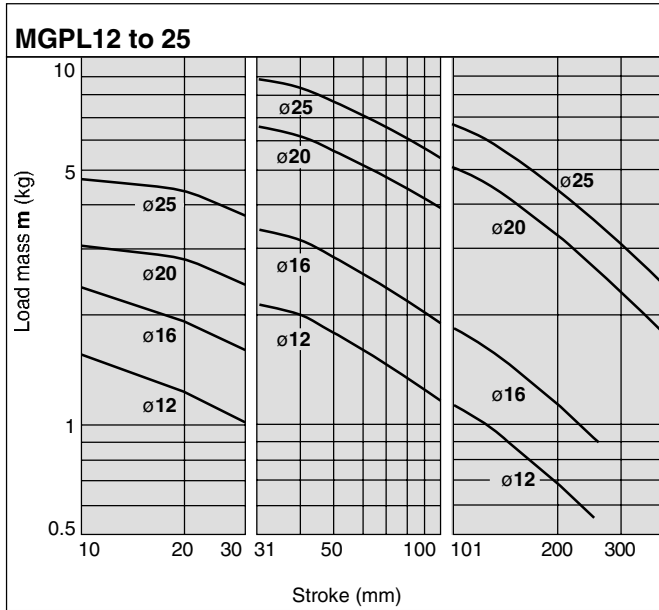

(18) $\ell = 100$ mm, $V = 200$ mm/s or less

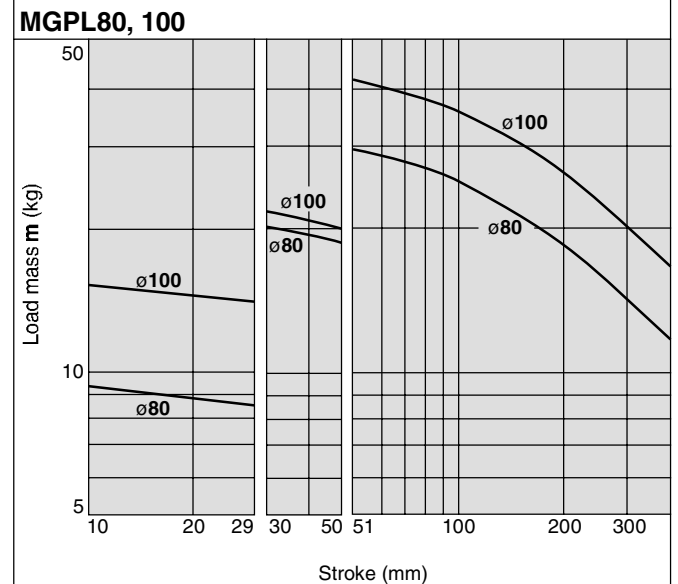
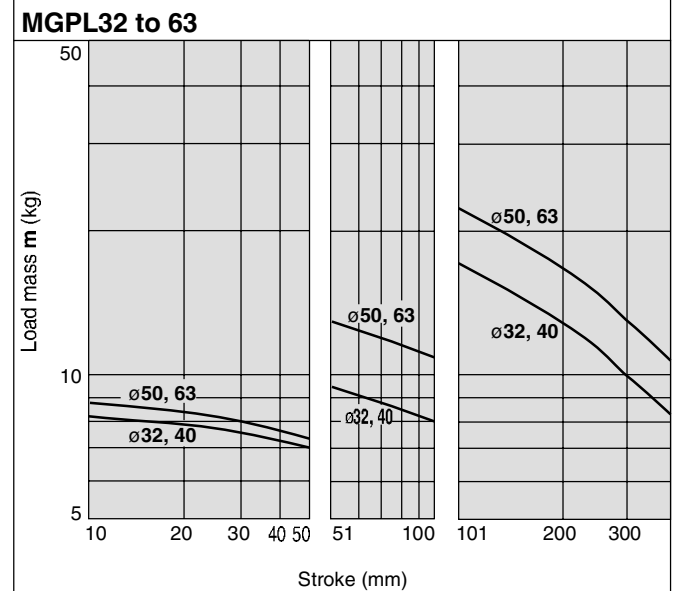
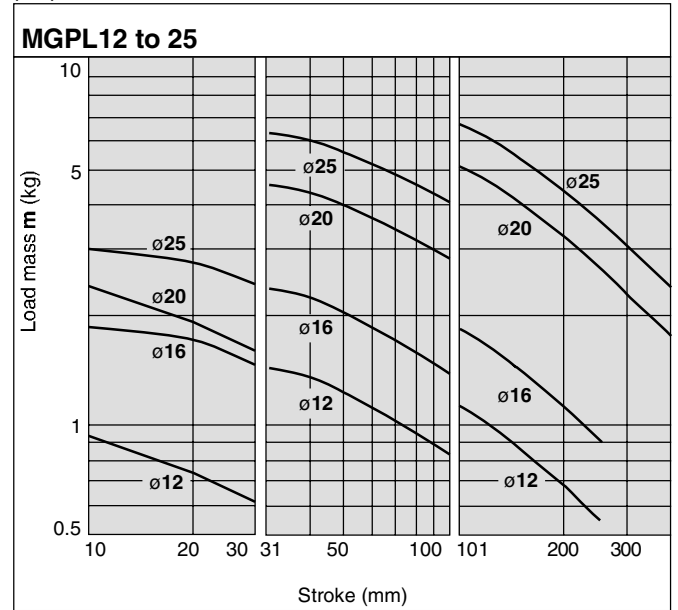

Horizontal Mounting (Ball Bushing)

(19) $\ell = 50$ mm, $V = 400$ mm/s

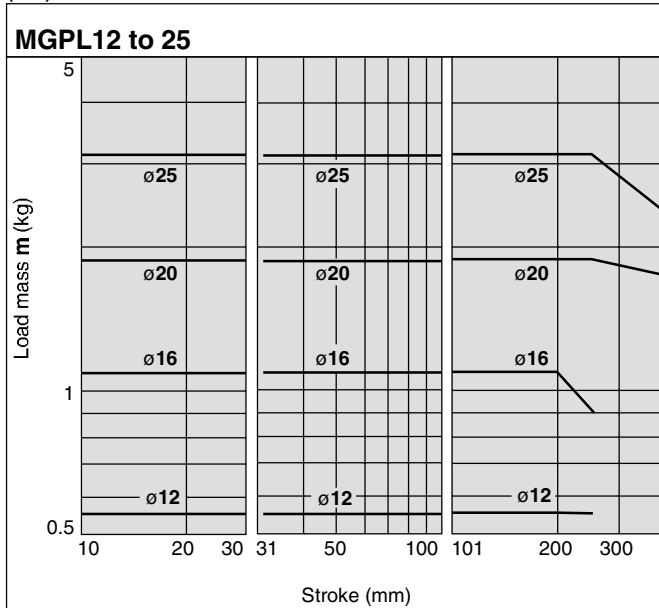

(20) $\ell = 100$ mm, $V = 400$ mm/s

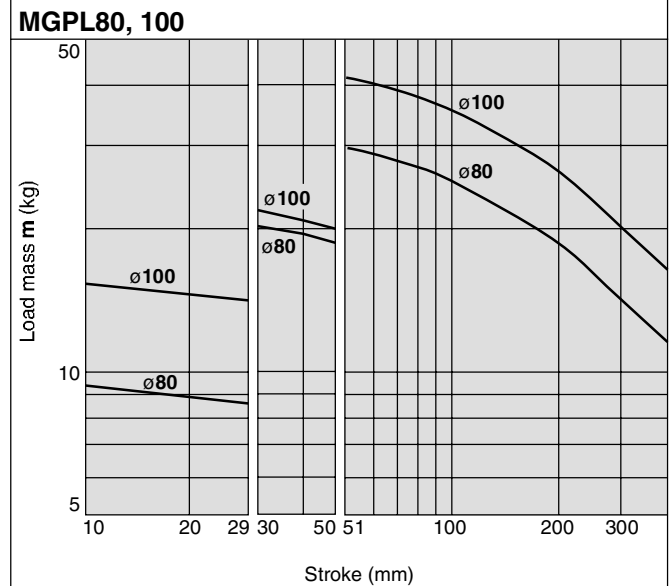
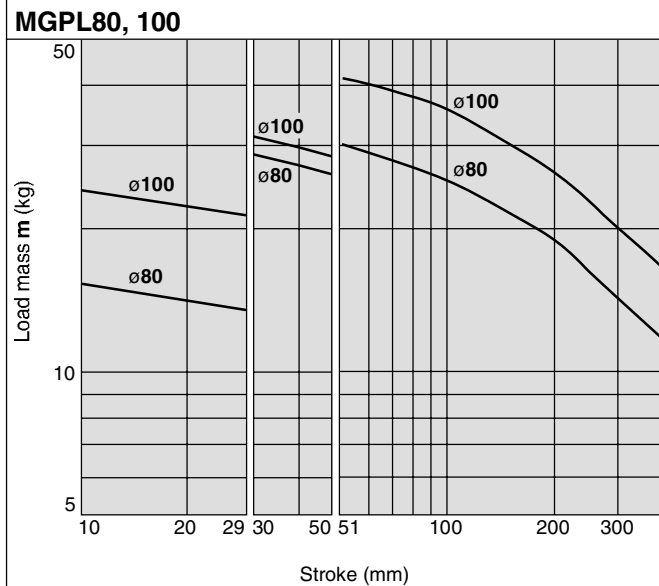
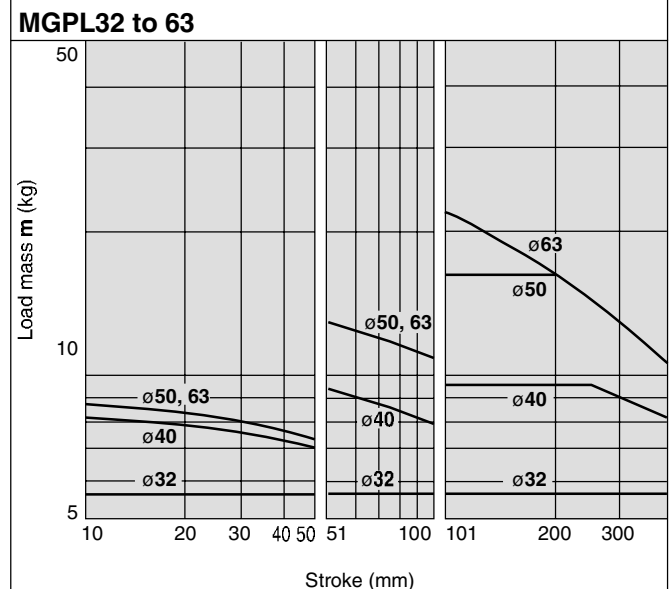
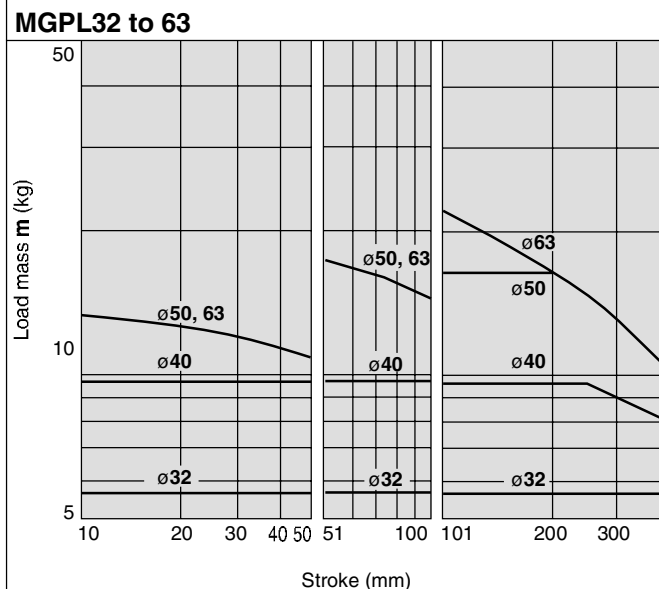
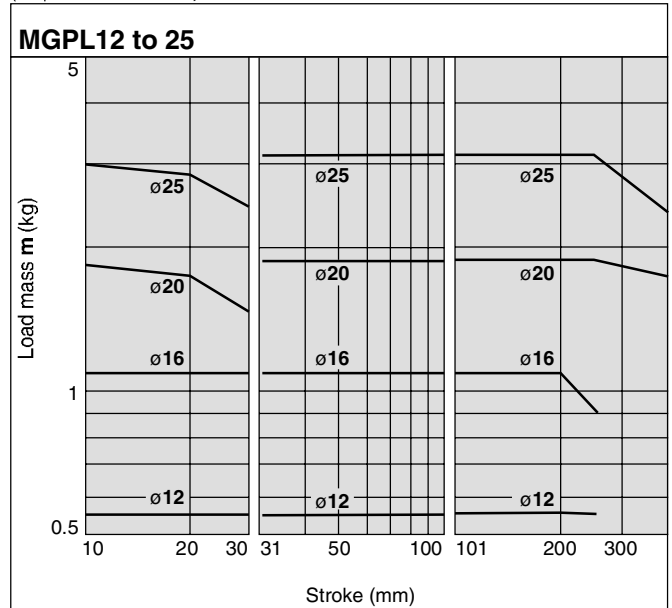

Series MGP

Operating Range when Used as Stopper

Bore Size: $\phi 12$ to 25/MGPM12 to 25 (Slide bearing)

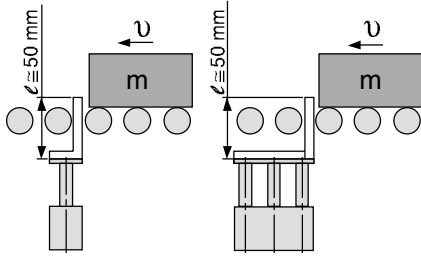

* When selecting a model with a longer l dimension, be sure to choose a bore size which is sufficiently large.

⚠ Caution

Caution on handling

- Note 1) When using as a stopper, select a model with 30 stroke or less.
 Note 2) Model MGPL (Ball bushing bearing) cannot be used as a stopper.

MGPM12 to 25 (Slide bearing)

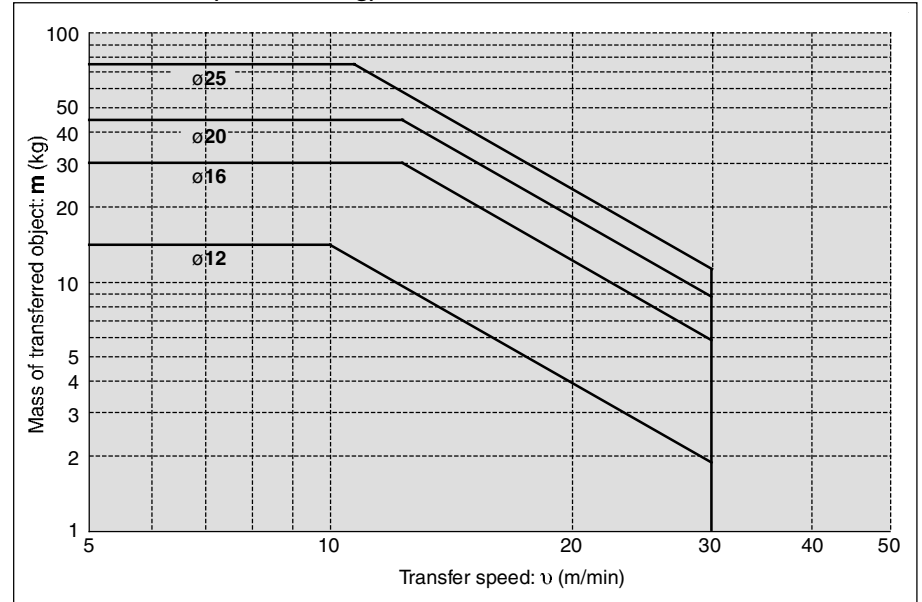

Bore Size: $\phi 32$ to 100/MGPM32 to 100 (Slide bearing)

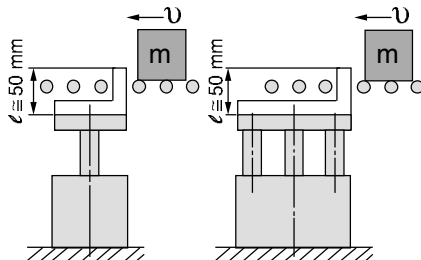

* When selecting a model with a longer l dimension, be sure to choose a bore size which is sufficiently large.

⚠ Caution

Caution on handling

- Note 1) When using as a stopper, select a model with 50 stroke or less.
 Note 2) Model MGPL (Ball bushing bearing) cannot be used as a stopper.

MGPM32 to 100 (Slide bearing)

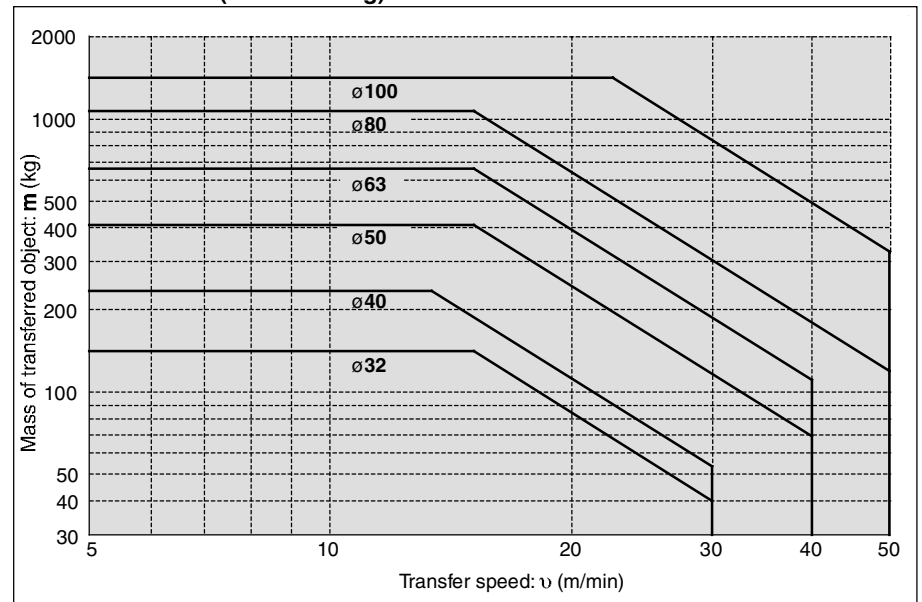

1. Water Resistant

Ideal for use in a machine tool environment exposed to coolants. Applicable for use in an environment with water splashing such as food processing and car wash equipment, etc.

Specifications

Applicable series		MGPM
Bearing type		Slide bearing
Bore size (mm)		20, 25, 32, 40, 50, 63, 80, 100
Cushion	MGPM□□R	Rubber bumper
	MGPM□□V	Without cushion

* Specifications other than above are the same as standard, basic style.
 (Note) Refer to pages 895 to 903 of Best Pneumatics No. 2 for details.

How to Order

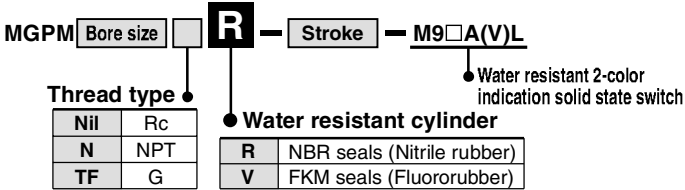

* Stainless steel parts are available as made-to-order products.
 * Piston rod and guide rod are made of stainless steel.

Dimensions

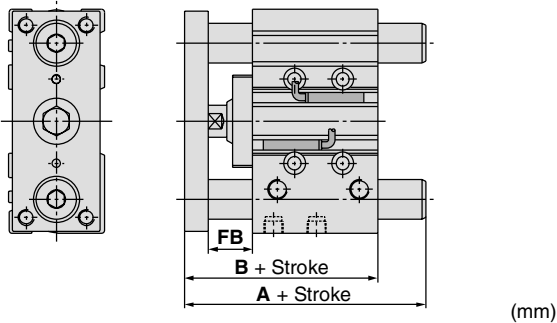

Bore size (mm)	A			B	FB
	50 st or less	Over 50 st to 200 st	Over 200 st		
20	66	97.5	135	66	19
25	67.5	99	136	67.5	20
32	109	114	152	71.5	22
40	109	114	152	78	22
50	117.5	129	172	83	23
63	117.5	129	172	88	23
80	121	148	199	102.5	24
100	141	166	207	120	29

* Other dimensions are the same as standard type.

2. Copper and fluorine-free (For CRT manufacturing process)

To prevent the influence of copper ions or halogen ions during CRT manufacturing processes, copper and fluorine materials are not used in the component parts.

Specifications

Applicable series	MGPM	MGPL
Bearing type	Slide bearing	Ball bushing bearing
Bore size (mm)	12, 16, 20, 25, 32, 40, 50, 63, 80, 100	

* Specifications and dimensions other than above are the same as the standard, basic style.

How to Order

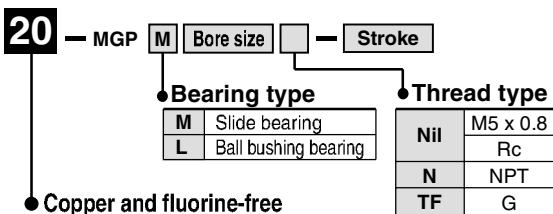

* For bore sizes 12 and 16, M5 x 0.8 is only available.

3. Clean Series

Applicable in a clean room environment. Ideal for use in conveyor lines for semiconductor (LSI), liquid crystal (LCD), liquid processing, pharmaceutical, and electronic parts, etc.

Specifications

Applicable series		MGPL							
Bearing type		Ball bushing bearing							
Bore size (mm)		12	16	20	25	32	40	50	63
Stroke (mm)		10 to 250		20 to 400			25 to 400		

* Specifications other than above are the same as standard, basic style.

How to Order

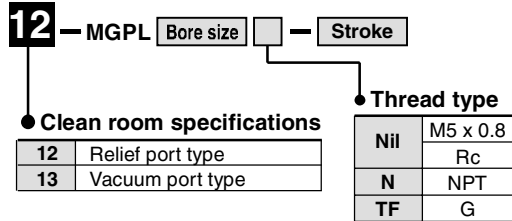

* For bore sizes 12 and 16, M5 x 0.8 is only available.

Dimensions

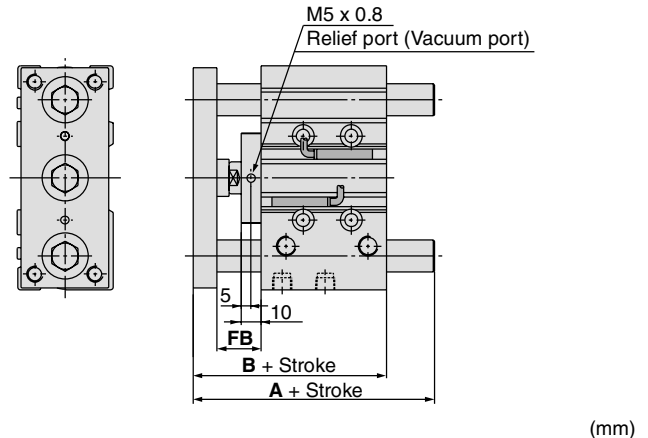

Bore size (mm)	A				B	FB
	30 st or less	Over 30 st to 100 st	Over 100 st to 200 st	Over 200 st		
12	56	68	98	98	55	18
16	62	78	108	108	59	18
20	76	93	117	135	66	19
25	82.5	98.5	117.5	135	66.5	19

Bore size (mm)	A				B	FB
	50 st or less	Over 50 st to 100 st	Over 100 st to 200 st	Over 200 st		
32	93	110	130	152	71.5	22
40	93	110	130	152	78	22
50	104	125	145	172	83	23
63	104	125	145	172	88	23

* Other dimensions are the same as standard products.

Series MGP

Construction/Series MGPM

MGPM12 to 25

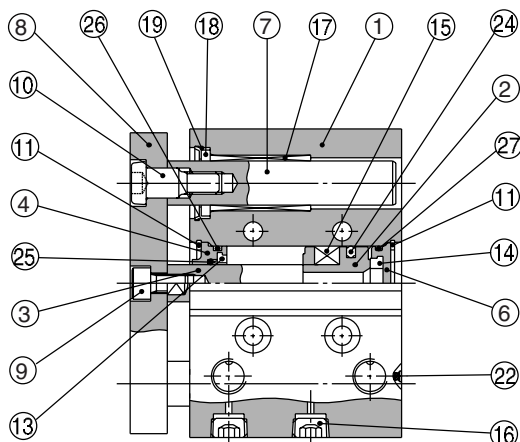

50 stroke or less

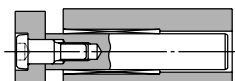

ø12, ø16 50 stroke or less

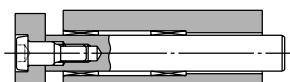

ø12, ø16 Over 50 stroke



ø20, ø25 Over 50 stroke

MGPM32 to 100

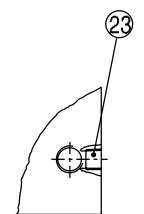
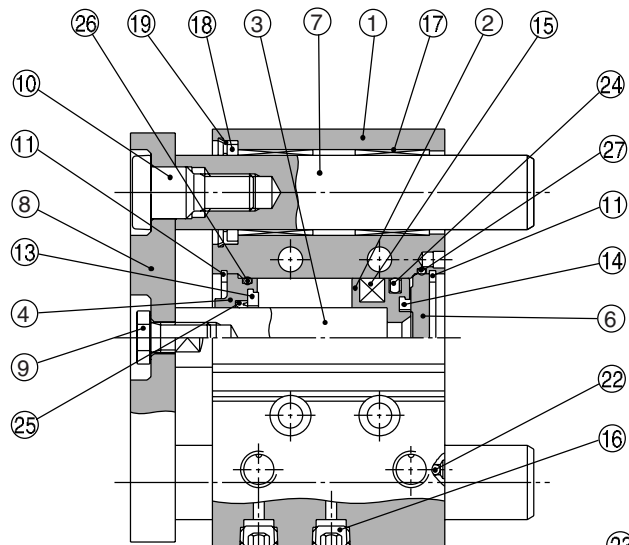

ø63 or more

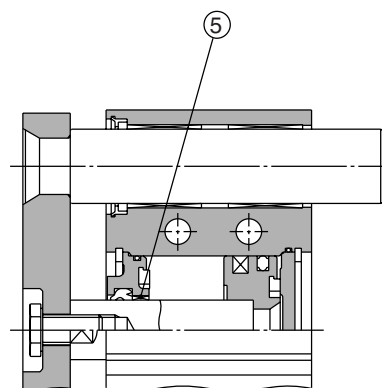

ø50 or more

Component Parts

No.	Description	Material	Note
1	Body	Aluminum alloy	Hard anodized
2	Piston	Aluminum alloy	Chromated
3	Piston rod	Stainless steel	ø12 to ø25
		Carbon steel	ø32 to ø100 Hard chrome plated
4	Collar	Aluminum bearing alloy	ø12 to ø40 Clear anodized
		Aluminum alloy casted	ø50 to ø100 Painted
5	Bushing	Babbitt	ø50 to ø100
6	Head cover	Aluminum alloy	ø12 to ø63 Chromated
			ø80 to ø100 Painted
7	Guide rod	Carbon steel	Hard chrome plated
8	Plate	Carbon steel	Nickel plated
9	Plate mounting bolt	Carbon steel	Nickel plated
10	Guide bolt	Carbon steel	Nickel plated
11	Retaining ring	Carbon tool steel	Phosphate coated
12	Retaining ring	Carbon tool steel	Phosphate coated
13	Bumper A	Urethane	
14	Bumper B	Urethane	
15	Magnet	-	
16	Plug	Carbon steel	ø12, ø16 Nickel plated
			ø20 to ø100
17	Slide Bearing	Babbitt	

Component Parts

No.	Description	Material	Note
18	Felt	Felt	
19	Holder	Resin	
20	Ball bushing		
21	Spacer	Aluminum alloy	
22	Steel ball	Carbon steel	ø12 to ø50
23	Plug	Carbon steel	ø63 to ø100 Nickel plated
24*	Piston seal	NBR	
25*	Rod seal	NBR	
26*	Gasket A	NBR	
27*	Gasket B	NBR	

Replacement Parts: Seal Kit

Bore size (mm)	Kit no.	Contents	Bore size (mm)	Kit no.	Contents
12	MGP12-PS	Set of nos. above 24, 25, 26, 27	40	MGP40-PS	Set of nos. above 24, 25, 26, 27
16	MGP16-PS		50	MGP50-PS	
20	MGP20-PS		63	MGP63-PS	
25	MGP25-PS		80	MGP80-PS	
32	MGP32-PS		100	MGP100-PS	

* Seal kit includes 24 to 27. Order the seal kit, based on each bore size.

* Since the seal kit does not include a grease pack, order it separately.

Grease pack part no.: GR-S-010 (10 g)

Construction/Series MGPL

MGPL12 to 25

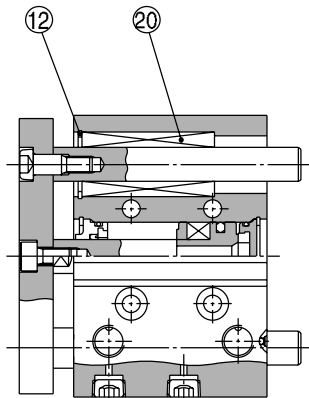

30 stroke or less

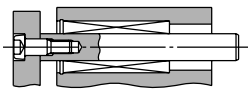

ø12, ø16 30 stroke or less

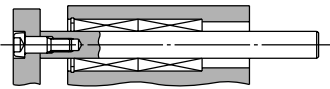

ø12, ø16 Over 30 stroke

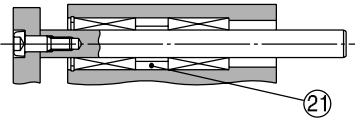

ø20, ø25 Over 100 stroke

MGPL32 to 100

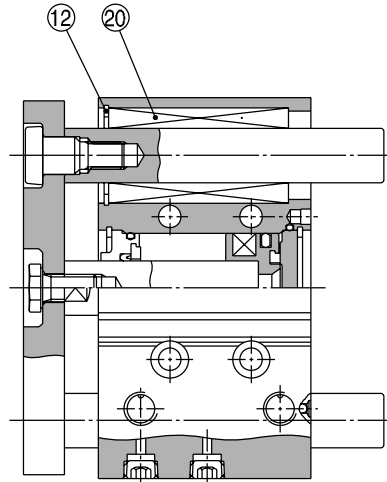

ø63 or more

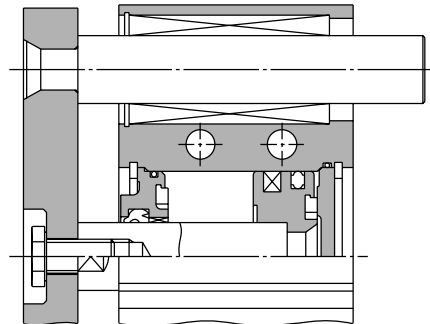

ø50 or more

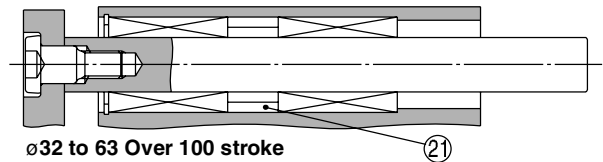

ø32 to 63 Over 100 stroke

Series MGP

MGPM, MGPL: $\phi 12$ to $\phi 25$

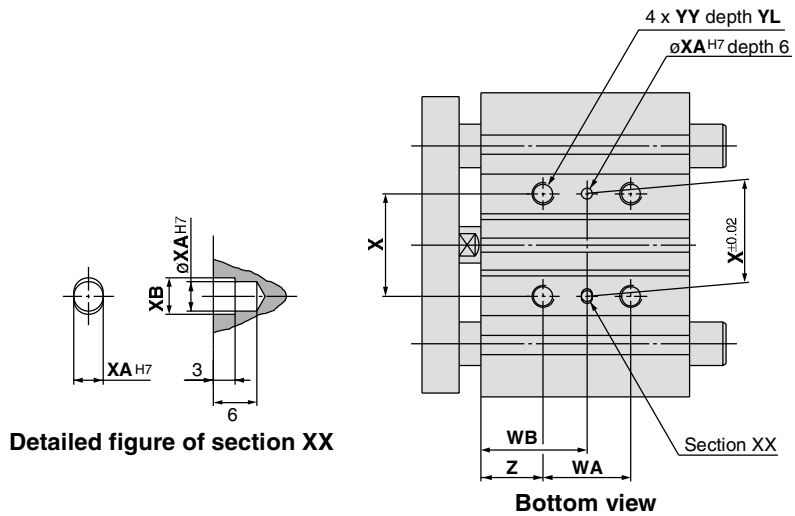

T-slot dimensions

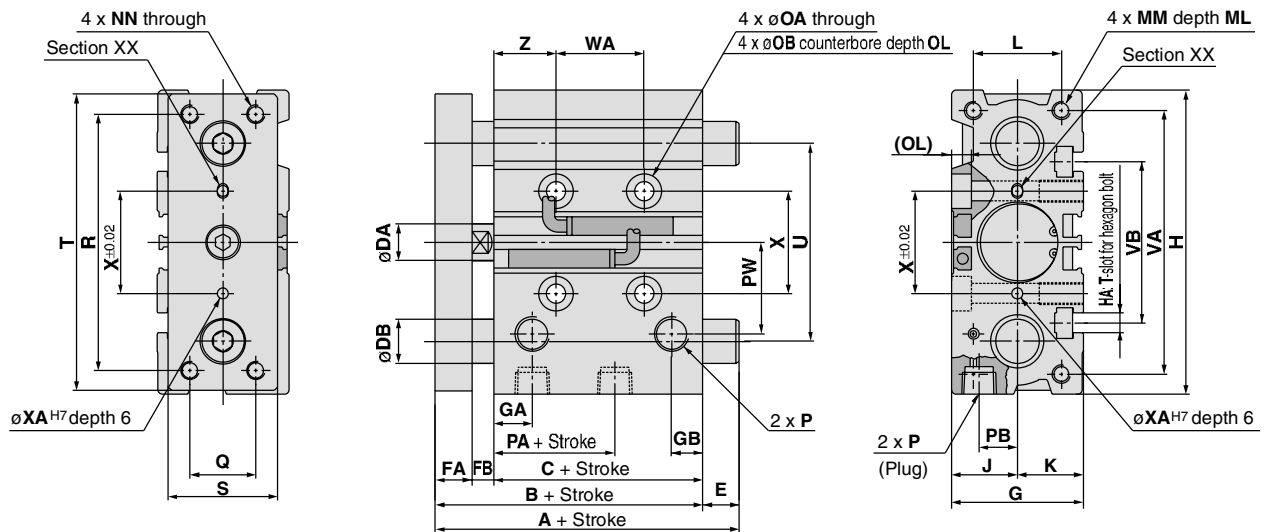
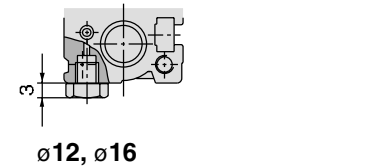
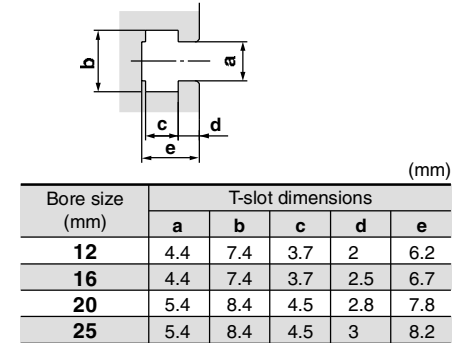

• For intermediate strokes other than standard strokes, refer to "Manufacture of Intermediate Stroke" on page 273.

• For bore sizes with $\phi 12$ and $\phi 16$ only, M5 x 0.8 is available.
• Rc, NPT, G port can be selected for bore sizes with $\phi 20$ or more. (Refer to page 272.)

MGPM, MGPL Common Dimensions

Bore size (mm)	Standard stroke (mm)	B	C	DA	FA	FB	G	GA	GB	H	HA	J	K	L	MM	ML	NN	OA	OB	OL	P		
																					Nil	N	TF
12	10, 20, 30, 40, 50, 75, 100	42	29	6	8	5	26	11	7.5	58	M4	13	13	18	M4 x 0.7	10	M4 x 0.7	4.3	8	4.5	M5 x 0.8	—	—
16	125, 150, 175, 200, 250	46	33	8	8	5	30	11	8	64	M4	15	15	22	M5 x 0.8	12	M5 x 0.8	4.3	8	4.5	M5 x 0.8	—	—
20	20, 30, 40, 50, 75, 100, 125, 150, 175, 200, 250, 300, 350, 400	53	37	10	10	6	36	10.5	8.5	83	M5	18	18	24	M5 x 0.8	13	M5 x 0.8	5.4	9.5	5.5	Rc 1/8	NPT 1/8	G 1/8
25		53.5	37.5	12	10	6	42	11.5	9	93	M5	21	21	30	M6 x 1.0	15	M6 x 1.0	5.4	9.5	5.5	Rc 1/8	NPT 1/8	G 1/8

Bore size (mm)	PA	PB	PW	Q	R	S	T	U	VA	VB	WA			WB			X	XA	XB	YY	YL	Z				
											30 st or less	Over 30 st to 100 st	Over 100 st to 200 st	Over 200 st to 300 st	30 st or less	Over 30 st to 100 st							Over 100 st to 200 st	Over 200 st to 300 st		
12	13	8	18	14	48	22	56	41	50	37	20	40	110	200	—	15	25	60	105	—	23	3	3.5	M5 x 0.8	10	5
16	15	10	19	16	54	25	62	46	56	38	24	44	110	200	—	17	27	60	105	—	24	3	3.5	M5 x 0.8	10	5
20	12.5	10.5	25	18	70	30	81	54	72	44	24	44	120	200	300	29	39	77	117	167	28	3	3.5	M6 x 1.0	12	17
25	12.5	13.5	30	26	78	38	91	64	82	50	24	44	120	200	300	29	39	77	117	167	34	4	4.5	M6 x 1.0	12	17

MGPM (Slide bearing) A, DB, E Dimensions

Bore size (mm)	A				DB	E			
	50 st or less	Over 50 st to 100 st	Over 100 st to 200 st	Over 200 st		50 st or less	Over 50 st to 100 st	Over 100 st to 200 st	Over 200 st
12	42	60.5	85	85	8	0	18.5	43	43
16	46	64.5	95	95	10	0	18.5	49	49
20	53	84.5	84.5	122	12	0	31.5	31.5	69
25	53.5	85	85	122	16	0	31.5	31.5	68.5

MGPL (Ball bushing bearing) A, DB, E Dimensions

Bore size (mm)	A				DB	E			
	30 st or less	Over 30 st to 100 st	Over 100 st to 200 st	Over 200 st		30 st or less	Over 30 st to 100 st	Over 100 st to 200 st	Over 200 st
12	43	55	85	85	6	1	13	43	43
16	49	65	95	95	8	3	19	49	49
20	63	80	104	122	10	10	27	51	69
25	69.5	85.5	104.5	122	13	16	32	51	68.5

MGPM, MGPL: $\phi 32$ to $\phi 63$

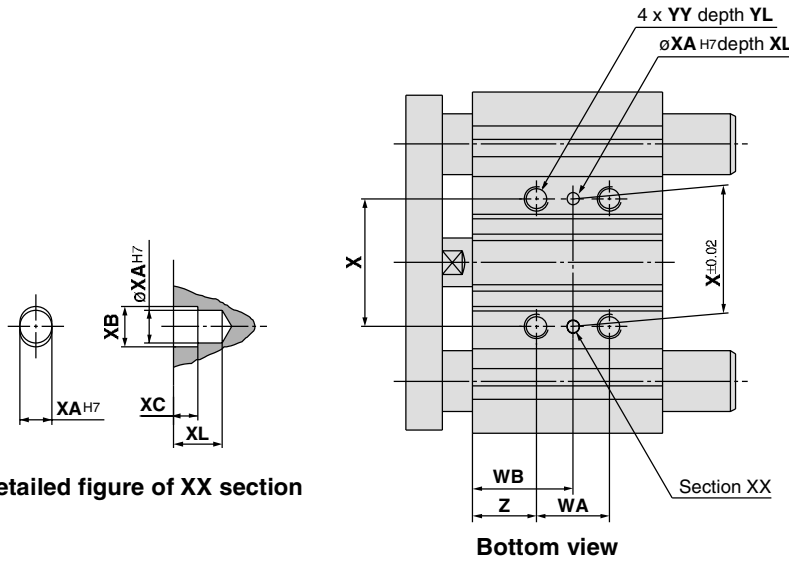

Detailed figure of XX section

Bottom view

T-slot dimensions

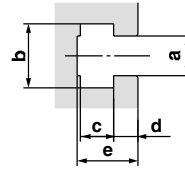

Bore size (mm)	T-slot dimensions (mm)				
	a	b	c	d	e
32	6.5	10.5	5.5	3.5	9.5
40	6.5	10.5	5.5	4	11
50	8.5	13.5	7.5	4.5	13.5
63	11	17.8	10	7	18.5

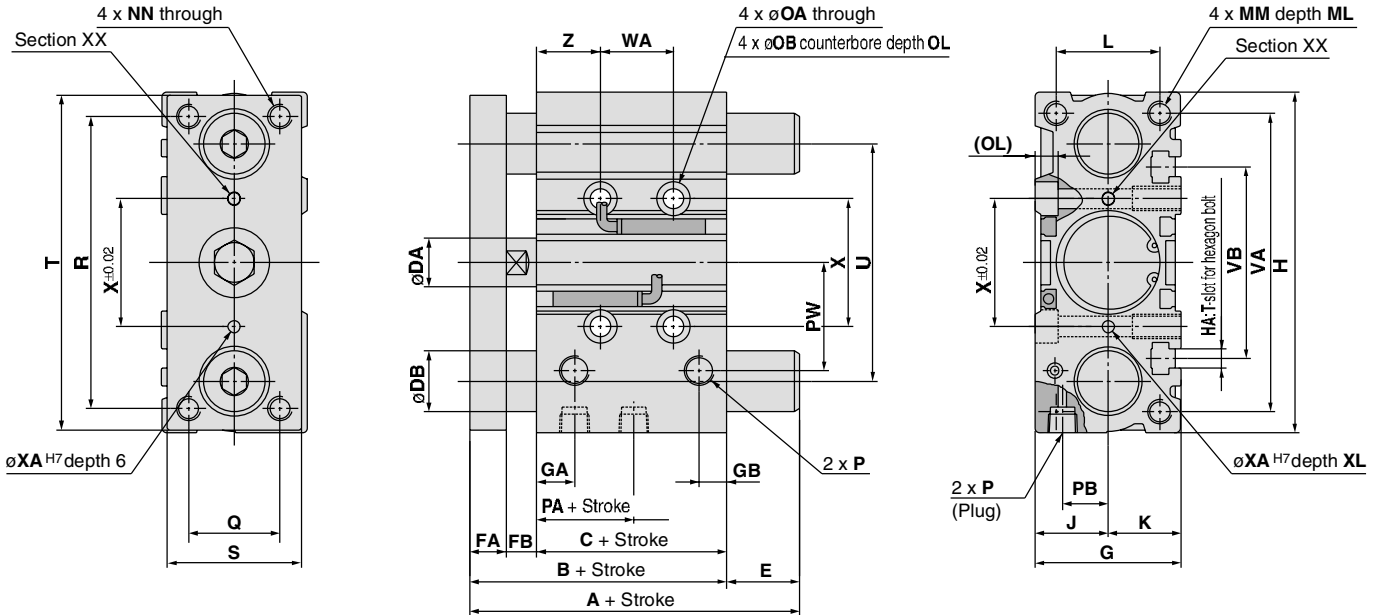

• For intermediate strokes other than standard strokes, refer to "Manufacture of Intermediate Stroke" on page 273.

• Choice of Rc, NPT, G port is possible. (Refer to page 272.)

MGPM, MGPL Common Dimensions

Bore size (mm)	Standard stroke (mm)	B	C	DA	FA	FB	G	GA	GB	H	HA	J	K	L	MM	ML	NN	OA	OB	OL	P		
																					Nil	N	TF
32	25, 50, 75	59.5	37.5	16	12	10	48	12.5	9	112	M6	24	24	34	M8 x 1.25	20	M8 x 1.25	6.6	11	7.5	Rc 1/8	NPT 1/8	G 1/8
40	100, 125, 150	66	44	16	12	10	54	14	10	120	M6	27	27	40	M8 x 1.25	20	M8 x 1.25	6.6	11	7.5	Rc 1/8	NPT 1/8	G 1/8
50	175, 200, 250	72	44	20	16	12	64	14	11	148	M8	32	32	46	M10 x 1.5	22	M10 x 1.5	8.6	14	9	Rc 1/4	NPT 1/4	G 1/4
63	300, 350, 400	77	49	20	16	12	78	16.5	13.5	162	M10	39	39	58	M10 x 1.5	22	M10 x 1.5	8.6	14	9	Rc 1/4	NPT 1/4	G 1/4

Bore size (mm)	PA	PB	PW	Q	R	S	T	U	VA	VB	WA					WB					X	XA	XB	XC	XL	YY	YL	Z
											25 st or less	Over 25 st to 100 st	Over 100 st to 200 st	Over 200 st to 300 st	Over 300 st	25 st or less	Over 25 st to 100 st	Over 100 st to 200 st	Over 200 st									
32	7	15	35.5	30	96	44	110	78	98	63	24	48	124	200	300	33	45	83	121	171	42	4	4.5	3	6	M8 x 1.25	16	21
40	13	18	39.5	30	104	44	118	86	106	72	24	48	124	200	300	34	46	84	122	172	50	4	4.5	3	6	M8 x 1.25	16	22
50	9	21.5	47	40	130	60	146	110	130	92	24	48	124	200	300	36	48	86	124	174	66	5	6	4	8	M10 x 1.5	20	24
63	14	28	58	50	130	70	158	124	142	110	28	52	128	200	300	38	50	88	124	174	80	5	6	4	8	M10 x 1.5	20	24

MGPM (Slide bearing) A, DB, E Dimensions (mm)

Bore size (mm)	A			DB	E		
	50 st or less	Over 50 st to 200 st	Over 200 st		50 st or less	Over 50 st to 200 st	Over 200 st
32	97	102	140	20	37.5	42.5	80.5
40	97	102	140	20	31	36	74
50	106.5	118	161	25	34.5	46	89
63	106.5	118	161	25	29.5	41	84

MGPL (Ball bushing bearing) A, DB, E Dimensions (mm)

Bore size (mm)	A				DB	E			
	50 st or less	Over 50 st to 100 st	Over 100 st to 200 st	Over 200 st		50 st or less	Over 50 st to 100 st	Over 100 st to 200 st	Over 200 st
32	81	98	118	140	16	21.5	38.5	58.5	80.5
40	81	98	118	140	16	15	32	52	74
50	93	114	134	161	20	21	42	62	89
63	93	114	134	161	20	16	37	57	84

Series MGP

MGPM, MGPL: $\phi 80$, $\phi 100$

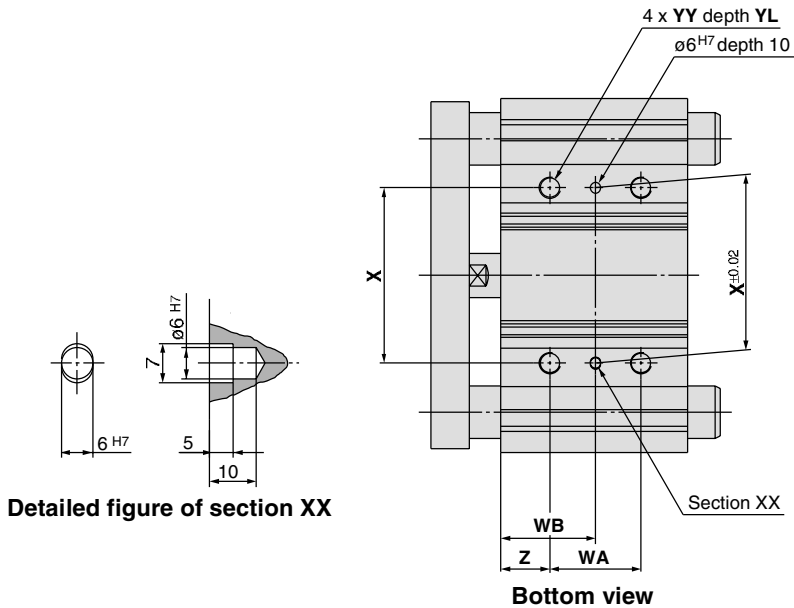

T-slot dimensions

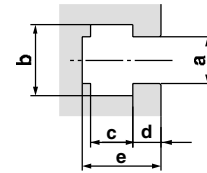

Bore size (mm)	T-slot dimensions				
	a	b	c	d	e
80	13.3	20.3	12	8	22.5
100	15.3	23.3	13.5	10	30

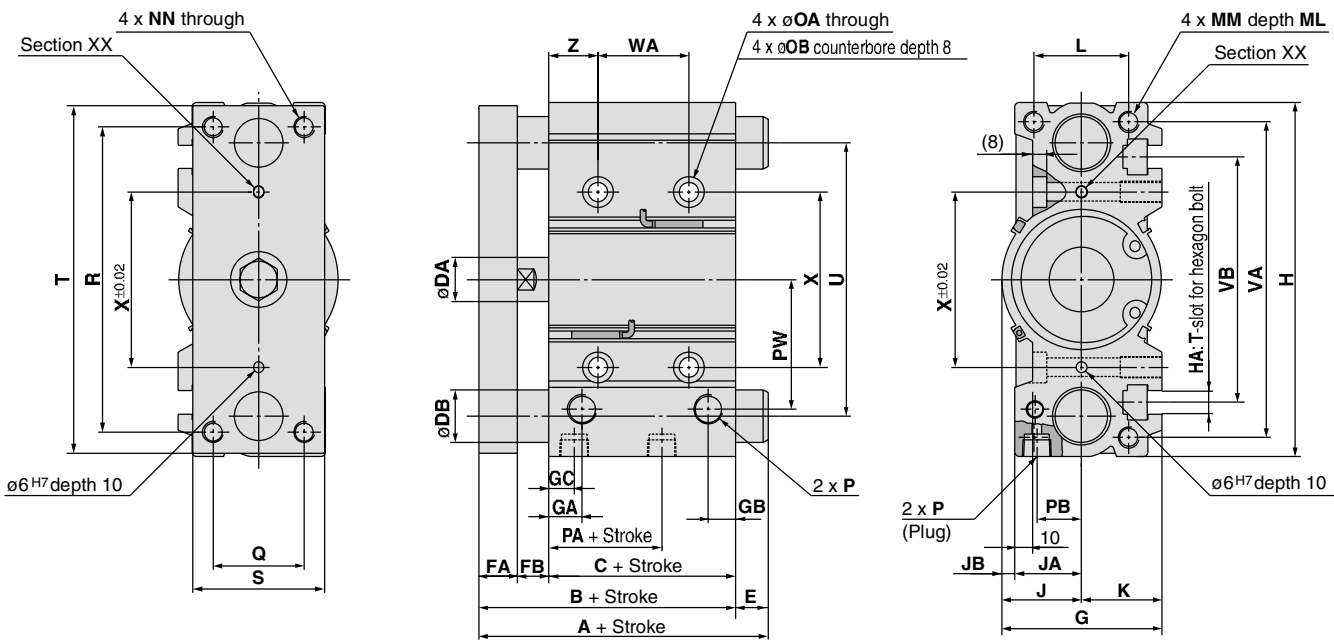

• For intermediate strokes other than standard strokes, refer to "Manufacture of Intermediate Stroke" on page 273.



• Choice of Rc, NPT, G port is possible. (Refer to page 272.)

MGPM, MGPL Common Dimensions

Bore size (mm)	Standard stroke (mm)	B	C	DA	FA	FB	G	GA	GB	GC	H	HA	J	JA	JB	K	L	MM	ML	NN	OA	OB	P		
																							Nil	N	TF
80	25, 50, 75, 100, 125, 150, 175, 200	96.5	56.5	25	22	18	91.5	19	15.5	14.5	202	M12	45.5	38	7.5	46	54	M12 x 1.75	25	M12 x 1.75	10.6	17.5	Rc 3/8	NPT 3/8	G 3/8
100	250, 300, 350, 400	116	66	30	25	25	111.5	23	19	18	240	M14	55.5	45	10.5	56	62	M14 x 2.0	31	M14 x 2.0	12.5	20	Rc 3/8	NPT 3/8	G 3/8

Bore size (mm)	PA	PB	PW	Q	R	S	T	U	VA	VB	WA					WB					X	YY	YL	Z
											25 st or less	Over 25 st to 100 st	Over 100 st to 200 st	Over 200 st to 300 st	Over 300 st	25 st or less	Over 25 st to 100 st	Over 100 st to 200 st	Over 200 st to 300 st	Over 300 st				
80	14.5	25.5	74	52	174	75	198	156	180	140	28	52	128	200	300	42	54	92	128	178	100	M12 x 1.75	24	28
100	17.5	32.5	89	64	210	90	236	188	210	166	48	72	148	220	320	35	47	85	121	171	124	M14 x 2.0	28	11

MGPM (Slide bearing) A, DB, E Dimensions

Bore size (mm)	A			DB	E		
	50 st or less	Over 50 st to 200 st	Over 200 st		50 st or less	Over 50 st to 200 st	Over 200 st
80	115	142	193	30	18.5	45.5	96.5
100	137	162	203	36	21	46	87

MGPL (Ball bushing bearing) A, DB, E Dimensions

Bore size (mm)	A			DB	E		
	25 st or less	Over 25 st to 50 st	Over 50 st to 200 st		25 st or less	Over 25 st to 50 st	Over 50 st to 200 st
80	109.5	130	160	25	13	33.5	96.5
100	121	147	180	30	5	31	87

Gentle Automatic Solution Sdn Bhd

Tel :603-80237743 Fax :603-80239743 Email :sales@gentle.com.my http://www.gentle.com.my