

Booster Regulator/Air Tank

New

RoHS

Increase factory air pressure by up to 4 times!
Air-only operation requires no power supply,
reduces heat generation, and
allows easy installation.

NEW

Renewed model with
pressure increase ratio
2 to 4 times (VBA11A)

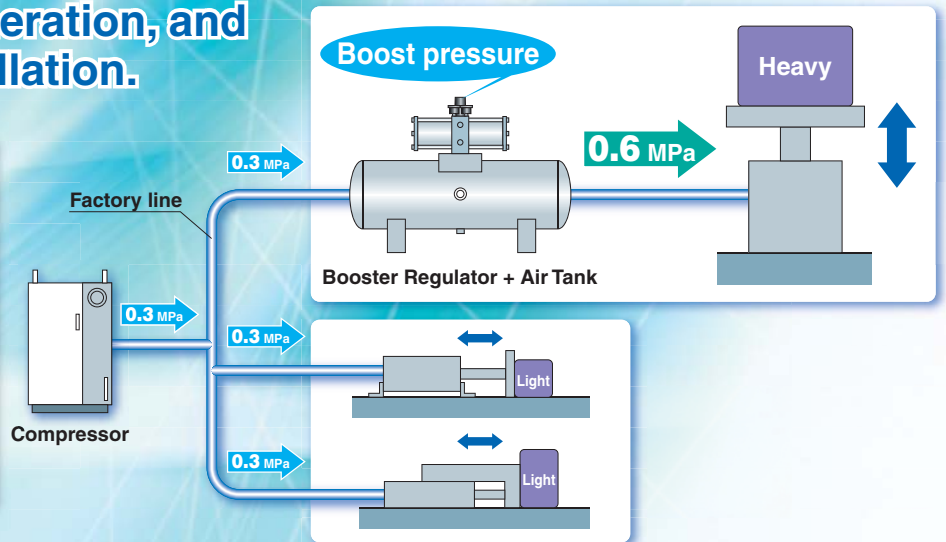

No power supply or wiring needed

There is no need to
install dedicated
electrical wiring.



Easy installation

Simply insert the unit
in the air line.
Requires far less
space than installing
the compressor.

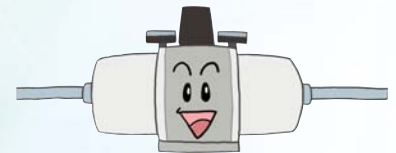

Low heat generation

Very little heat is
generated because
no electricity is
used, and there is
no impact on
cylinders, solenoid
valves, etc.

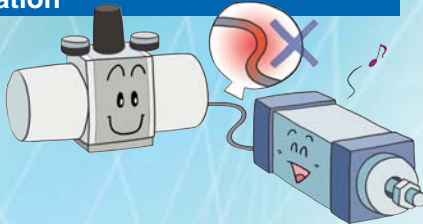

Air-only operation

Operation is safe
because no
electricity is used.

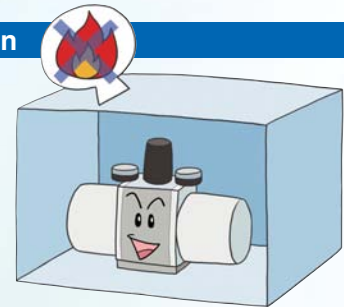

Booster Regulator/Series VBA



Air Tank/Series VBAT

Series VBA/VBAT



CAT.NAS11-96D

Booster Regulator Series VBA

Improved service life

Doubled
that of the conventional model

- Floating piston structure (PAT. PEND)
 - Grease retaining groove*
- * Except VBA10A, 11A

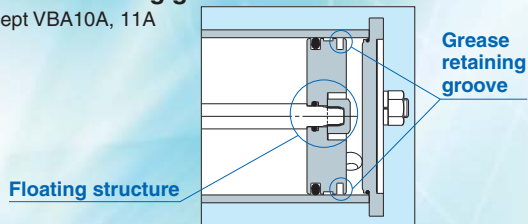

Reduced noise

Reduced by **13 dB (A)**
compared with the conventional model

- Metal noise reduced by a bumper on the impact part of the switching valve
- Exhaust noise reduced by a high-noise reduction silencer

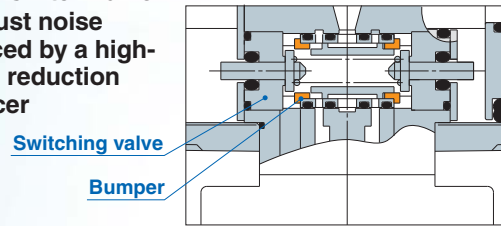

Improved reliability

Built-in mesh filter at IN port

- Prevents operation failure due to foreign matter.

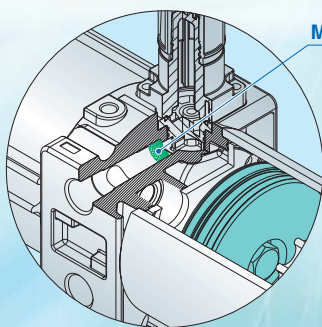

Anti-condensation

Integrated air-feeding tube with the main tube

- Mitigates condensation caused by cooling during exhaust expansion.

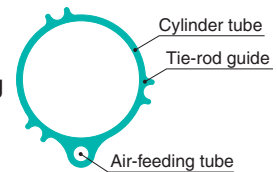

NEW

Elbow silencer added* (Option)

More compact installation can be achieved.

* Except VBA2□A, 4□A



1/8" gauge ports

- Allows use of standard fittings for remote pressure monitoring, etc.
- * Gauge ports changed from 1/16" to 1/8" (VBA1□A, 2□A)

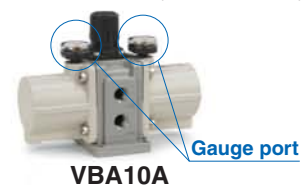

Air-operated type









Max. operating pressure 1.6 MPa (232 psi)



Fourfold pressure increase type

NEW



Body size	Pressure increase ratio	Twice		2 to 4 times
	Operation	Handle-operated type (Direct operation)		Handle-operated type (Direct operation)
	Set pressure range	0.2 to 1.0 MPa (30 to 145 psi)	0.2 to 1.6 MPa (30 to 232 psi) [0.2 to 2.0 MPa (30 to 290 psi)]	0.2 to 2.0 MPa (30 to 290 psi)
1/4"			VBA10A-02 [0.2 to 2.0 MPa (30 to 290 psi)] 	VBA11A-02 
3/8"	VBA20A-03 		VBA22A-03 	
1/2"	VBA40A-04 	VBA43A-04 [0.2 to 1.6 MPa (30 to 232 psi)] 	VBA42A-04 	

Air Tank Series VBAT

Perfect fit with a booster regulator

This is an air tank to which a booster regulator can be connected compactly. It can be used alone as a tank.

Product lineup

Select a product from the series below according to the operating conditions.

Model	VBAT05A1-X11	VBAT10A1-X11
Tank capacity	5 L (1.3 gal.)	10 L (2.6 gal.)
Max. operating pressure	2 MPa (290 psi)	
Material	Carbon steel	



Booster Regulator Series VBA



How to Order



Made to Order
(For details, refer to page 11.)

VBA 40A - 04 -

Body size

10A	1/4", Handle-operated type	Pressure increase ratio: Twice
20A	3/8", Handle-operated type	
40A	1/2", Handle-operated type	
22A	3/8", Air-operated type	
42A	1/2", Air-operated type	
43A	1/2", Max. operating pressure 1.6 MPa (232 psi)	Pressure increase ratio: 2 to 4 times
11A	1/4", Handle-operated type	

Semi-standard

Symbol	Semi-standard
Nil	Standard product
Z (Note)	Pressure unit on the product name label and pressure gauge: psi

Note) Thread type: NPT, NPTF
Under the new measurement law, the pressure unit of "psi" on the pressure gauges cannot be used in Japan.

Option

Symbol	Option
Nil	None
G	Pressure gauge
N	Silencer
S	High-noise reduction silencer (Note)
GN	Pressure gauge, Silencer
GS	Pressure gauge, High-noise reduction silencer (Note)
LN	Elbow silencer (Note)
LS	Elbow high-noise reduction silencer (Note)
GLN	Pressure gauge, Elbow silencer (Note)
GLS	Pressure gauge, Elbow high-noise reduction silencer (Note)

Note) Refer to "Combination of Thread Type and Options."

Thread type (Note)

Symbol	Thread type
Nil	Rc
F	G
N	NPT
T	NPTF

Note) Thread types apply to the IN, OUT, and EXH ports of the VBA1□A and to the IN, OUT, EXH, and gauge ports of the VBA2□A and VBA4□A.

The gauge ports of the VBA1□A are Rc thread type regardless of the thread type indication.

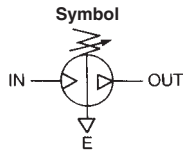

VBA10A-02



VBA11A-02



VBA20A-03



VBA22A-03



VBA40A-04



VBA42A-04



VBA43A-04

Port size

Symbol	Port size	Applicable series
02	1/4"	VBA1□A
03	3/8"	VBA2□A
04	1/2"	VBA4□A

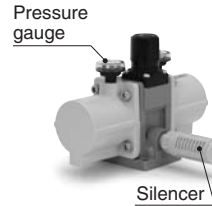

Silencer

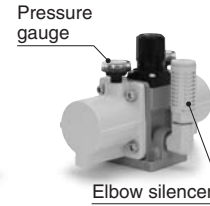

Elbow silencer

Combination of Thread Type and Options

Body size	Thread type	Option										Semi-standard		
		Nil	G	N	S	GN	GS	LN	LS	GLN	GLS	Nil	-Z	
10A 11A	Nil	●	●	●	●	●	●	●	●	●	●	●	●	—
	F	●	●	●	●	●	●	●	●	●	●	●	●	—
	N	●	●	●	—	●	—	●	—	●	—	●	●	—
	T	●	●	●	—	●	—	●	—	●	—	●	●	—
20A 22A	Nil	●	●	●	●	●	●	—	—	—	—	—	—	—
	F	●	●	●	●	●	●	—	—	—	—	—	—	—
	N	●	●	●	●	●	●	—	—	—	—	—	—	—
	T	●	●	●	●	●	●	—	—	—	—	—	—	—
40A 42A 43A	Nil	●	●	●	●	●	●	—	—	—	—	—	—	—
	F	●	●	●	●	●	●	—	—	—	—	—	—	—
	N	●	●	●	●	●	●	—	—	—	—	—	—	—
	T	●	●	●	●	●	●	—	—	—	—	—	—	—

Air tank combination chart

Air tank	Booster regulator	
	VBA1□A	VBA2□A
VBAT05A1-X11	●	—
VBAT10A1-X11	●	●

See page 13 for details

Standard Specifications

Model	VBA10A-02	VBA20A-03	VBA40A-04	VBA22A-03	VBA42A-04	VBA43A-04	VBA11A-02
Fluid	Compressed air						
Pressure increase ratio	Twice					Twice	Twice to 4 times
Pressure adjustment mechanism	Handle-operated with relief mechanism ^{Note 1)}			Air-operated		Handle-operated with relief mechanism ^{Note 1)}	
Max. flow rate ^{Note 2)}	230 L/min (ANR) (8.1 SCFM)	1000 L/min (ANR) (35.3 SCFM)	1900 L/min (ANR) (67.1 SCFM)	1000 L/min (ANR) (35.3 SCFM)	1900 L/min (ANR) (67.1 SCFM)	1600 L/min (ANR) (56.5 SCFM)	70 L/min (ANR) (2.4 SCFM)
Set pressure range	0.2 to 2.0 MPa (29 to 290 psi)	0.2 to 1.0 MPa (29 to 145 psi)		0.2 to 1.0 MPa (29 to 145 psi)		0.2 to 1.6 MPa (29 to 232 psi)	0.2 to 2.0 MPa (29 to 290 psi)
Supply pressure range	0.1 to 1.0 MPa (15 to 145 psi)						
Proof pressure	3 MPa (435 psi)	1.5 MPa (217.5 psi)		1.5 MPa (217.5 psi)		2.4 MPa (348 psi)	3 MPa (435 psi)
Port size (IN/OUT/EXH: 3 locations)	1/4	3/8	1/2	3/8	1/2	1/2	1/4
Pressure gauge port size (IN/OUT: 2 locations)	1/8 Rc	1/8	1/8	1/8	1/8	1/8	1/8 Rc
Ambient and fluid temperature	2 to 50°C (35.6 to 122°F) (No freezing)						
Installation	Horizontal						
Lubrication	Grease (Non-lube)						
Weight	0.84 kg (1.9 lb)	3.9 kg (8.6 lb)	8.6 kg (19 lb)	3.9 kg (8.6 lb)	8.6 kg (19 lb)	8.6 kg (19 lb)	0.89 kg (2.0 lb)

Note 1) If the OUT pressure is higher than the set pressure by the handle, excessive pressure is exhausted from the back of the handle.

Note 2) Flow rate at IN= OUT= 0.5 MPa (72.5 psi). The pressure varies depending on the operating conditions. Refer to "Flow Characteristics" on pages 3 and 4.

Options/Part No.

Pressure Gauge, Silencer (When thread type is Rc or G.)

Model		VBA10A-02	VBA20A-03	VBA40A-04	VBA22A-03	VBA42A-04	VBA43A-04	VBA11A-02
Description		VBA10A-F02	VBA20A-F03	VBA40A-F04	VBA22A-F03	VBA42A-F04	VBA43A-F04	VBA11A-F02
Pressure gauge	G	G27-20-01	G36-10-01		KT-VBA22A-7	G36-10-01	G27-20-01	G27-20-01
Silencer	N	AN200-02	AN300-03	AN400-04	AN300-03	AN400-04	AN400-04	AN200-02
High-noise reduction silencer	S	ANA1-02	ANA1-03	ANA1-04	ANA1-03	ANA1-04	ANA1-04	ANA1-02
Elbow for silencer	L	KT-VBA10A-18	—	—	—	—	—	KT-VBA10A-18

Note 1) In the case of options GN, two pressure gauges and one silencer are included in the same container as accessories.

Note 2) KT-VBA22A-7 is a pressure gauge with fitting. (Please order two units when using with IN and OUT.)

Pressure Gauge, Silencer (When thread type is NPT or NPTF.)

Model		VBA10A-N02*	VBA20A-N03*	VBA40A-N04*	VBA22A-N03*	VBA42A-N04*	VBA43A-N04*	VBA11A-N02*
Description		VBA10A-T02*	VBA20A-T03*	VBA40A-T04*	VBA22A-T03*	VBA42A-T04*	VBA43A-T04*	VBA11A-T02*
		*: when "-Z"	*: when "-Z"	*: when "-Z"	*: when "-Z"	*: when "-Z"	*: when "-Z"	*: when "-Z"
Pressure gauge *: when Nil	G	G27-20-01	G36-10-N01		KT-VBA22A-7N	G36-10-N01	G27-20-N01	G27-20-01
Pressure gauge *: when "-Z" ^{Note 4)}		G27-P20-01	G36-P10-N01		KT-VBA22A-8N	G36-P10-N01	G27-P20-N01	G27-P20-01
Silencer	N	AN200-N02	AN300-N03	AN400-N04	AN300-N03	AN400-N04	AN400-N04	AN200-N02
High-noise reduction silencer	S	—	ANA1-N03	ANA1-N04	ANA1-N03	ANA1-N04	ANA1-N04	—
Elbow for silencer	L	KT-VBA10A-18N	—	—	—	—	—	KT-VBA10A-18N

Note 1) In the case of options GN, two pressure gauges and one silencer are included in the same container as accessories.

Note 2) KT-VBA22A-7N, KT-VBA22A-8N are pressure gauges with fittings. (Please order two units when using with IN and OUT.)

Note 3) Under the new measurement law, the pressure unit of "psi" on the pressure gauges cannot be used in Japan.

Note 4) Pressure unit on the pressure gauge: psi

Related Products/Part No.

Mist Separator, Exhaust Cleaner

Model		For VBA10A-02 For VBA11A-02	For VBA20A-03 For VBA22A-03	For VBA40A-04 For VBA42A-04 For VBA43A-04
Mist separator		AM250C-02	AM450C-04, 06	AM550C-06, 10
Exhaust cleaner		AMC310-03	AMC510-06	AMC610-10

Note) Refer to page 12 for air tanks, Best Pneumatics No. 5 for mist separators and Best Pneumatics No. 6 for exhaust cleaners.

Refer to the separate operation manual for the connection method.

Design

Caution

1. System configuration

- The IN port of the booster regulator has metallic mesh to prevent dust from entering the booster regulator. However, it cannot remove dust continuously or separate drainage. Make sure to install a mist separator (AM series) on the inlet side of the booster regulator.
- The booster regulator has a sliding part inside, and it generates dust. Also, install an air purification device such as an air filter or a mist separator on the outlet side as necessary.
- Connect a lubricator to the outlet side, because the accumulated oil in the booster regulator may result in a malfunction.

2. Exhaust air measures

- Provide a dedicated pipe to release the exhaust air from each booster regulator. If exhaust air is converged into a pipe, the back pressure that is created could cause improper operation.
- Depending on the necessity, install a silencer or an exhaust cleaner on the exhaust port of the booster regulator to reduce the exhaust noise.

3. Maintenance space

- Allow the sufficient space for maintenance and inspection.

Series VBA

VBA10A

Flow-rate Characteristics

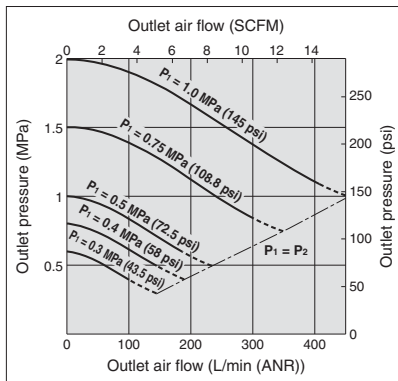

Pressure Characteristics

Inlet pressure: 0.7 MPa (101.5 psi) (Representative value)
 Outlet pressure: 1.0 MPa (145 psi)
 Flow rate: 20 L/min (ANR) (0.71 SCFM)

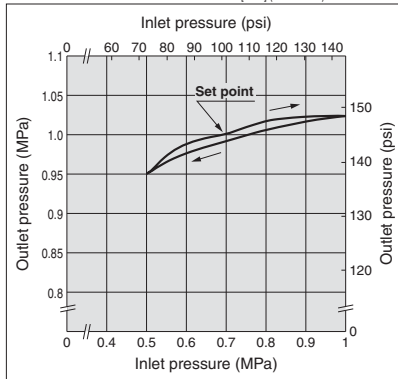

Charge Characteristics

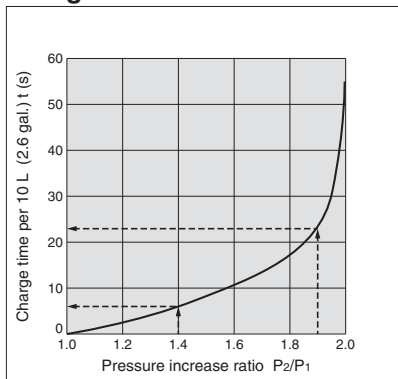

VBA10A

- The time required to charge tank pressure from 0.7 MPa to 0.95 MPa at 0.5 MPa supply pressure:

$$\frac{P_2}{P_1} = \frac{0.7}{0.5} = 1.4 \quad \frac{P_2}{P_1} = \frac{0.95}{0.5} = 1.9$$

With the pressure increase ratio from 1.4 to 1.9, the charge time of 23 – 6 = 17 sec. (t) is given by the graph. Then, the charge time (T) for a 10 L tank:

$$T = t \times \frac{V}{10} = 17 \times \frac{10}{10} = 17 \text{ (s)}$$

VBA20A, 22A

Flow-rate Characteristics

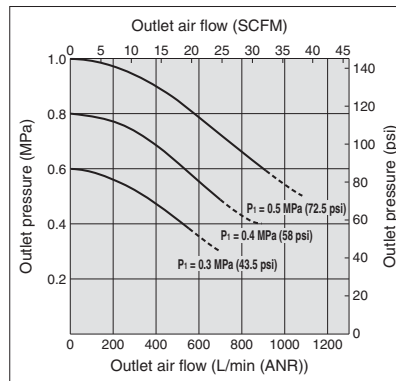

Pressure Characteristics

Inlet pressure: 0.7 MPa (101.5 psi) (Representative value)
 Outlet pressure: 1.0 MPa (145 psi)
 Flow rate: 20 L/min (ANR) (0.71 SCFM)

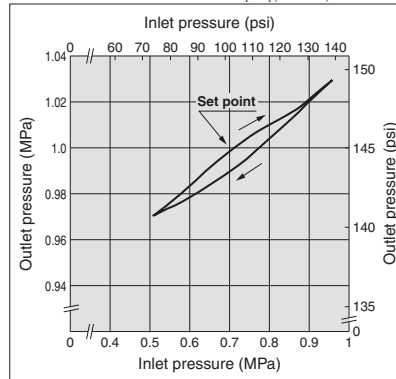

Charge Characteristics

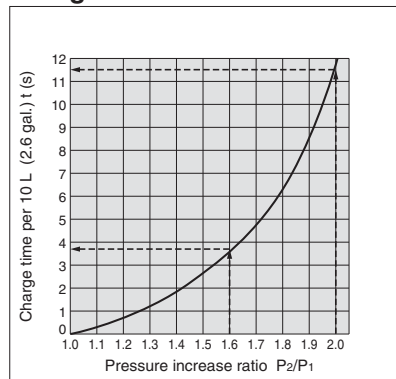

VBA20A, 22A

- The time required to charge tank pressure from 0.8 MPa to 1.0 MPa at 0.5 MPa supply pressure:

$$\frac{P_2}{P_1} = \frac{0.8}{0.5} = 1.6 \quad \frac{P_2}{P_1} = \frac{1.0}{0.5} = 2.0$$

With the pressure increase ratio from 1.6 to 2.0, the charge time of 11.5 – 3.8 = 7.7 sec. (t) is given by the graph. Then, the charge time (T) for a 100 L tank:

$$T = t \times \frac{V}{10} = 7.7 \times \frac{100}{10} = 77 \text{ (s)}$$

VBA40A, 42A

Flow-rate Characteristics

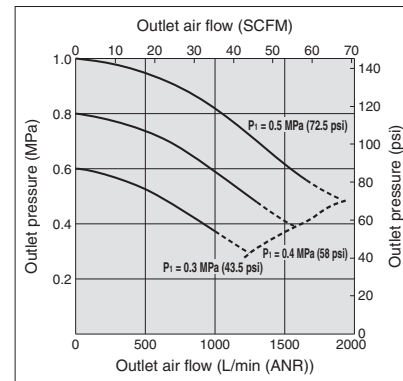

Pressure Characteristics

Inlet pressure: 0.7 MPa (101.5 psi) (Representative value)
 Outlet pressure: 1.0 MPa (145 psi)
 Flow rate: 20 L/min (ANR) (0.71 SCFM)

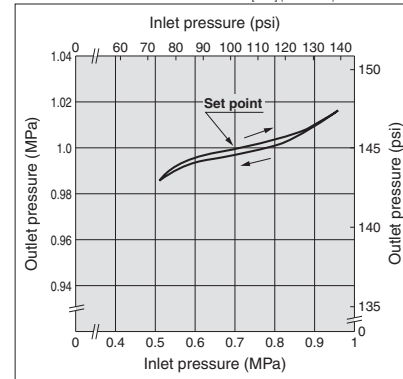

Charge Characteristics

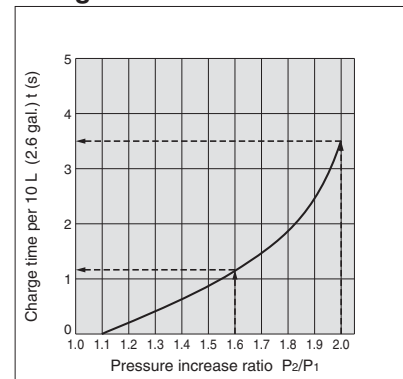

VBA40A, 42A

- The time required to charge tank pressure from 0.8 MPa to 1.0 MPa at 0.5 MPa supply pressure:

$$\frac{P_2}{P_1} = \frac{0.8}{0.5} = 1.6 \quad \frac{P_2}{P_1} = \frac{1.0}{0.5} = 2.0$$

With the pressure increase ratio from 1.6 to 2.0, the charge time of 3.5 – 1.1 = 2.4 sec. (t) is given by the graph. Then, the charge time (T) for a 100 L tank:

$$T = t \times \frac{V}{10} = 2.4 \times \frac{100}{10} = 24 \text{ (s)}$$

VBA43A

Flow-rate Characteristics

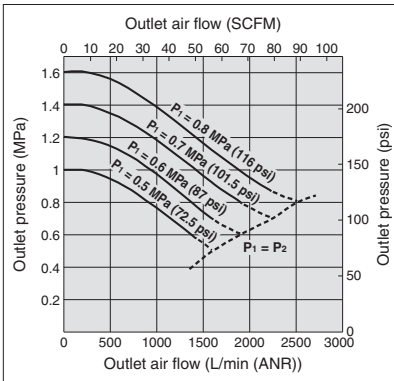

Pressure Characteristics
 Inlet pressure: 0.7 MPa (101.5 psi)
 Outlet pressure: 1.0 MPa (145 psi) (Representative value)
 Flow rate: 20 L/min (ANR) (0.71 SCFM)

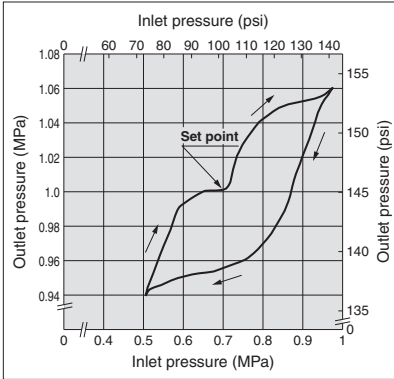

Charge Characteristics

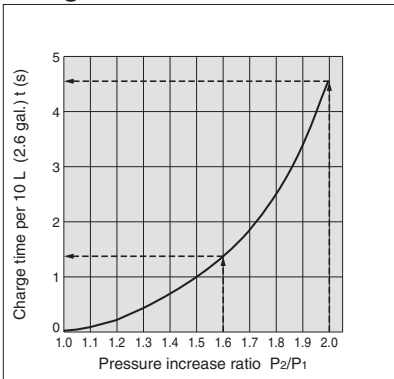

VBA43A

- The time required to charge tank pressure from 0.8 MPa to 1.0 MPa at 0.5 MPa supply pressure:

$$\frac{P_2}{P_1} = \frac{0.8}{0.5} = 1.6 \quad \frac{P_2}{P_1} = \frac{1.0}{0.5} = 2.0$$

With the pressure increase ratio from 1.6 to 2.0, the charge time of 4.5 – 1.3 = 3.2 sec. (t) is given by the graph. Then, the charge time (T) for a 100 L tank:

$$T = t \times \frac{V}{10} = 3.2 \times \frac{100}{10} = 32 \text{ (s).}$$

VBA11A

Flow-rate Characteristics

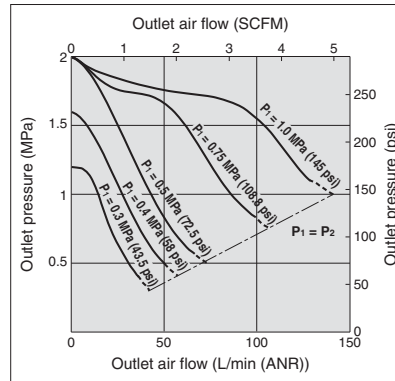

Pressure Characteristics
 Inlet pressure: 0.6 MPa (87 psi)
 Outlet pressure: 2.0 MPa (290 psi) (Representative value)
 Flow rate: 10 L/min (ANR) (0.35 SCFM)

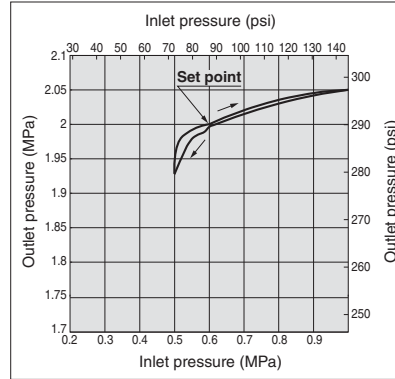

Charge Characteristics

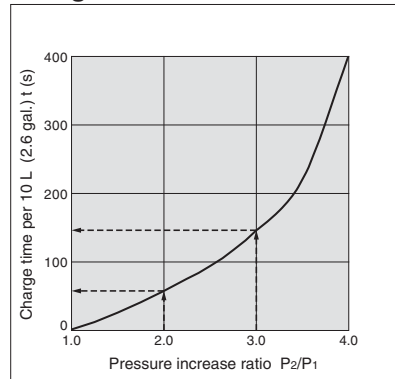

VBA11A

- The time required to charge pressure in the tank from 1.0 MPa to 1.5 MPa at 0.5 MPa supply pressure:

$$\frac{P_2}{P_1} = \frac{1.0}{0.5} = 2.0 \quad \frac{P_2}{P_1} = \frac{1.5}{0.5} = 3.0$$

With the pressure increase ratio from 2.0 to 3.0, the charge time of 147 – 58 = 89 sec. (t) is given by the graph. Then, the charge time (T) for a 10 L tank:

$$T = t \times \frac{V}{10} = 89 \times \frac{10}{10} = 89 \text{ (s).}$$

Pulsation/Pulsation is decreased by using tank.

If the outlet capacity is undersized, pulsation may occur.

VBAT05A1-X11

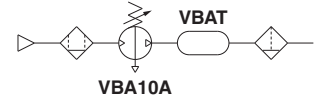
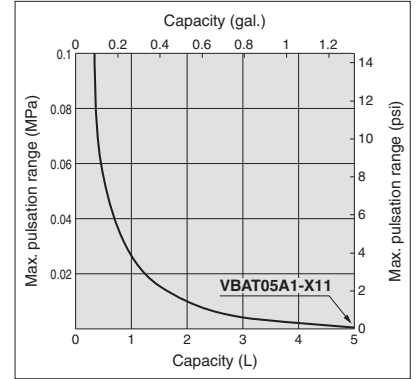

VBAT10A1-X11

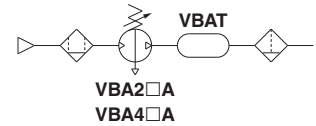
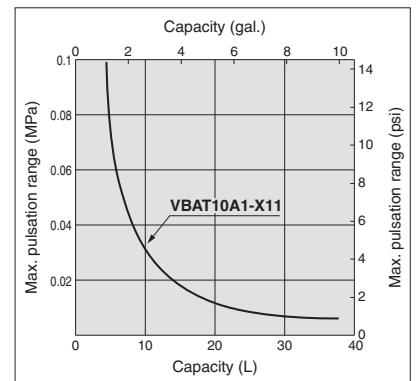

Conditions:
 Inlet pressure: 0.5 MPa
 Outlet set pressure: 1 MPa
 Flow rate: Between 0 and max. flow rate

- Performance of air tank
 - Alleviates the pulsation generated on the outlet side.
 - Manages supply air to be consumed for short periods of time by storing air through raising the tank pressure.

Series VBA

Sizing (Sizing can be achieved with the SMC Pneumatic System Energy Saving Program Ver. 3.1) which can be downloaded from the SMC website: <http://www.smcworld.com/>

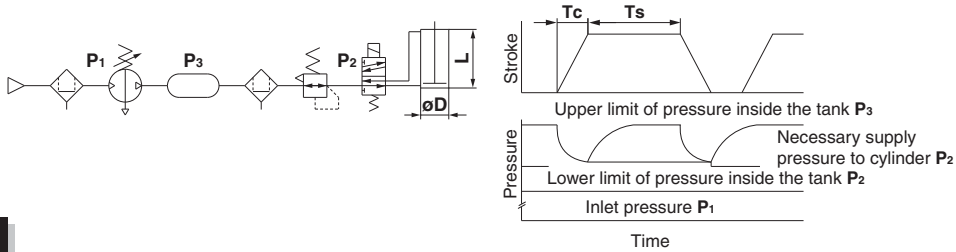

START

Provide requisite conditions for selection.

Necessary conditions:
D [mm]: Cylinder bore size
L [mm]: Cylinder stroke
W [mm/s]: Cylinder operating speed
C [pc.]: Number of cylinders
T_c [s]: Cylinder operating time
T_s [s]: Cylinder stop time
P₁ [MPa]: Inlet pressure
P₂ [MPa]^{Note 1)}: Necessary supply pressure to cylinder

Example:
 100
 100
 200
 1
 0.5
 30
 0.5
 0.8

Other conditions:
Q [L/min (ANR)]: Required air flow rate
Q_b [L/min (ANR)]: Outlet air flow rate of booster regulator
T_c [s]: Cylinder operating time
K: Cylinder double-acting: 2, single-acting: 1
P₃ [MPa]^{Note 2)}: Tank charge pressure
T₁ [s]: Time to charge (Time to charge to **P₂**)
T₂ [s]: Time to charge (Time to charge to **P₃**)
T [s]: Time to charge (Time to charge from **P₂** to **P₃**)
Z: Number of booster regulators

Note 1) **P₂** is the necessary supply pressure to a cylinder, and set the pressure below the lower limit of pressure inside the tank with a regulator. Adjust the pressure taking the maximum operating pressure of equipment in use into consideration.
 Note 2) **P₃** is the output pressure of the booster regulator, which is also the upper limit of charge pressure to the tank.

Calculate required air flow rate **Q**.

$$Q \text{ [L/min (ANR)]} = \frac{\pi \times D^2 \times W}{4 \times 10^6} \times \frac{(P_2 + 0.101)}{0.101} \times 60 \times C$$

$$Q = \frac{\pi \times 100^2 \times 200}{4 \times 10^6} \times \frac{(0.8 + 0.101)}{0.101} \times 60 \times 1 = 841 \text{ [L/min (ANR)]}$$

Select booster regulator size from flow-rate characteristics table.

VBA2□A: Q_b = 600 [L/min (ANR)]
VBA4□A: Q_b = 1050 [L/min (ANR)]
 Refer to "Flow-rate Characteristics" on pages 3 and 4.

Judgement of flow rate

NO: Need no tank [The **VBA4□A** can supply necessary pressure.]

YES [The **VBA2□A** cannot obtain necessary pressure.]

Obtain the tank capacity **V**.

$$V \text{ [L]} = \frac{(Q - Q_b/2) \times (T_c \times K/60)}{(P_3 - P_2) \times 9.9}$$

$$V = \frac{(841 - 600/2) \times (0.5 \times 2/60)}{(1.0 - 0.8) \times 9.9} = 4.6 \text{ [L]}$$

Select the tank capacity over **V**.

Select the **VBAT10A1-X11**, which can be directly connected to the **VBA2□A**.

Calculate time **T** from charge characteristics table.

Refer to "Charge Characteristics" on pages 3 and 4.

$$T \text{ [s]} = \left(\frac{V}{10}\right) \times \frac{T_2 - T_1}{Z}$$

$$T = \left(\frac{4.6}{10}\right) \times \frac{11.5 - 3.8}{1} = 3.5 \text{ [s]}$$

Judgement of charge time **T ≤ T_s**

NO [Extend stop time **T_s** up to charge time **T** or more.]
NO [Increase number of booster regulators (**Z**) to decrease **T**.]
YES

END

When running continuously for longer periods of time, confirm the life expectancy.
 When the life expectancy is shorter than required, select a larger sized booster regulator.

Caution

- Use the VBA11A (pressure increase ratio 4) with pressure increase ratio 2 to 4. Usage of pressure increase ratio below 2 is preferred for the VBA10A (pressure increase ratio 2). A stable operation and increased life expectancy will result.
- Inlet supply pressure volume is {approximately twice (pressure increase ratio 2), approx. 4 times (pressure increase ratio 4)} the volume of the outlet side. Booster regulator requires the inlet side volume which is the sum of the flow volume running into the outlet side and the volume exhausted from E port (for driving), because air is the power source.

Avoid pulsation. (Max. 0.05 MPa)

Select the tank from table below.

Tank part no.	Inner volume	Applicable combination model	
VBAT05A1-X11	5 L (1.3 gal.)	VBA1□A	—
VBAT10A1-X11	10 L (2.6 gal.)	VBA1□A	VBA2□A

Working Principle

The IN air passes through the check valve to **booster chambers A and B**. Meanwhile, air is supplied to **drive chamber B** via the governor and the switching valve. Then, the air pressure from **drive chamber B** and **booster chamber A** are applied to the piston, boosting the air in **booster chamber B**. As the piston travels, the boosted air is pushed via the check valve to the **OUT** side. When the piston reaches the end, the piston causes the switching valve to switch, so that **drive chamber B** is in the exhaust state and **drive chamber A** is in the supply state respectively. Then, the piston reverses its movement, this time, the pressures from **booster chamber B** and **drive chamber A** boosts the air in **booster chamber A** and sends it to the **OUT** side. The process described above is repeated to continuously supply highly pressurized air from the IN to the OUT side. The governor establishes the outlet pressure by handle operation and pressure adjustment in the drive chamber by feeding back the outlet pressure.

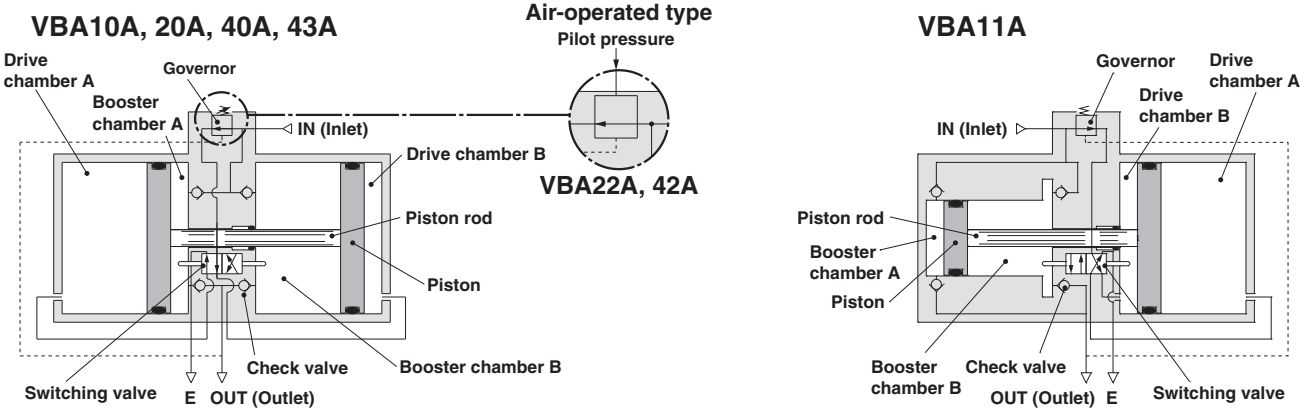

Circuit Example

- When only some of the machines in the plant require high-pressure air, booster regulators can be installed for only the equipment that requires it. This allows the overall system to use low-pressure air while accommodating machines requiring high-pressure air.

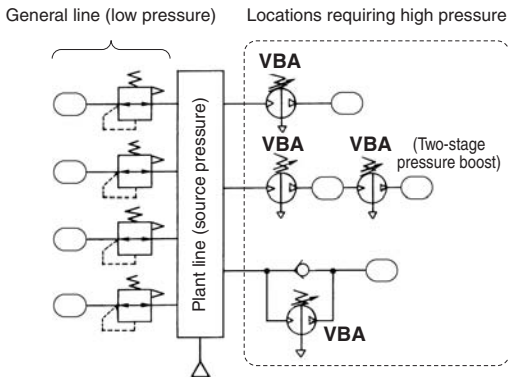

- When charging a tank or the like from a source at atmospheric pressure, a circuit with a check valve can be used to reduce the charge time by allowing air to pass through the check valve up to the inlet pressure.

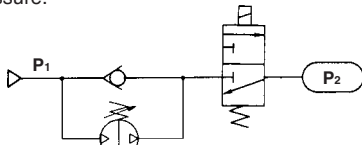

Initially, inlet pressure (P_1) passes through the check valve, fills P_2 , and results in $P_1 = P_2$.

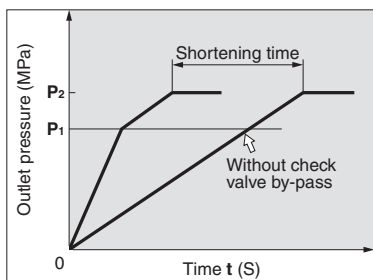

- When the actuator output is insufficient but space limitations prohibit switching to a larger cylinder diameter, a booster regulator can be used to increase the pressure. This makes it possible to boost the output without replacing the actuator.
- When a certain level of output is required but the cylinder size must be kept small so that the driver remains compact.

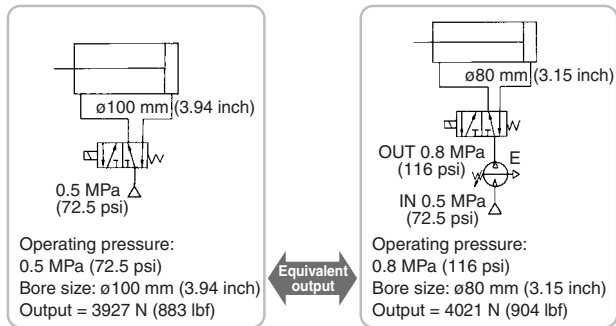

- When only one side of the cylinder is used for work, booster regulators can be installed only on the lines that require them to reduce the overall air consumption volume.

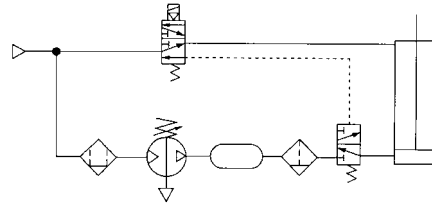

Design

⚠ Warning

1. Warning concerning abnormal outlet pressure

- If there is a likelihood of causing an outlet pressure drop due to unforeseen circumstances such as equipment malfunction, thus leading to a major problem, take safety measures on the system side.
- Because the outlet pressure could exceed its set range if there is a large fluctuation in the inlet pressure, leading to unexpected accidents, take safety measures against abnormal pressures.
- Operate the equipment within its maximum operating pressure and set pressure range.

2. Residual pressure measures

- Connect a 3-port valve to the OUT side of the booster regulator if the residual pressure must be released quickly from the outlet pressure side for maintenance, etc. (Refer to the diagram below.) The residual outlet pressure side cannot be released even if the 3-port valve is connected to the IN side because the check valve in the booster regulator will activate.

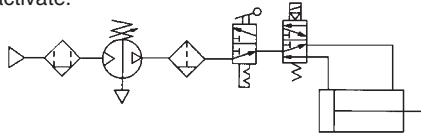

- After operation is finished, release the supply pressure at the inlet. This stops the booster regulator from moving needlessly and prevents operating malfunctions.

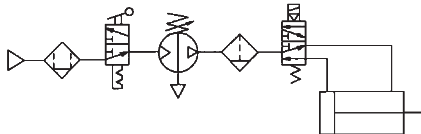

Selection

⚠ Caution

1. Check the specifications.

- Consider the operating conditions and operate this product within the specification range that is described in this catalog.

2. Selection

- Based on the conditions (such as pressure, flow rate, takt time) required for the outlet side of the booster regulator, select the size of the booster regulator in accordance with the selection procedures described in this catalog or model selection program.
- Use the VBA11A (pressure increase ratio 4) with pressure increase ratio 2 to 4. Usage of pressure increase ratio below 2 is preferred for the VBA10A (pressure increase ratio 2). A stable operation and increased life expectancy will result.
- Inlet supply pressure volume is {approximately twice (pressure increase ratio 2), approx. 4 times (pressure increase ratio 4)} the volume of the outlet side. Booster regulator requires the inlet side volume which is the sum of the flow volume running into the outlet side and the volume exhausted from E port (for driving), because air is the power source.
- When running continuously for longer periods of time, confirm the life expectancy. The life expectancy of a booster regulator is dependent upon the operational cycle. Thus, when used for driving cylinders, etc. in the outlet side, life expectancy will be reduced.
- Make sure the outlet pressure is set 0.1 MPa (15 psi) or higher than the inlet pressure. A pressure difference below 0.1 MPa (15 psi) makes the operation unstable and may result in a malfunction.

Mounting

⚠ Caution

1. Transporting

- When transporting this product, hold it lengthwise with both hands. Never hold it by the black handle that protrudes from the center because the handle could become detached from the body, causing the body to fall and leading to injury.

2. Installation

- Install this product so that the silver-colored tie-rods and cover are placed horizontally. If mounted vertically, it may result in a malfunction.
- Because the piston cycle vibration is transferred, use the following mounting bolts (VBA1: M5; VBA2, 4: M10) and tighten them with the specified torque (VBA1: 3 N·m (2.2 ft·lbf); VBA2, 4: 24 N·m (17.7 ft·lbf)).
- If the transmission of vibration is not preferred, insert an isolating rubber material before installation.
- Mount the pressure gauge with a torque of 7 to 9 N·m (5.2 to 6.6 ft·lbf).

Piping

⚠ Caution

1. Flushing

- Use an air blower to flush the piping to thoroughly remove any cutting chips, cutting oil, or debris from the piping inside, before connecting them. If they enter the inside of the booster regulator, they could cause the booster regulator to malfunction or its durability could be affected.

2. Piping size

- To bring the booster regulator's ability into full play, make sure to match the piping size to the port size.

Air Supply

⚠ Caution

1. Quality of air source

- Connect a mist separator to the inlet side near the booster regulator. If the quality of the compressed air is not thoroughly controlled, the booster regulator could malfunction (without being able to boost) or its durability could be affected.
- If dry air (atmospheric pressure dew point: -17°C (2°F) or less) is used, the life expectancy may be shortened because dry air will accelerate evaporation of grease inside.

Operating Environment

⚠ Caution

1. Installation location

- Do not install this product in an area that is exposed to rainwater or direct sunlight.
- Do not install in locations influenced by vibrations. If it must be used in such an area due to unavoidable circumstances, please contact SMC beforehand.

Handling

Caution

1. Setting the pressure on the handle-operated type

- If air is supplied to the product in the shipped state, the air will be released.
Set the pressure by quickly pulling up on the governor handle, releasing the lock, and rotating the handle in the direction of the arrow (+).
- There is an upper and lower limit for the handle rotation. If over-rotating the handle even after reaching to the limit, the internal parts may be damaged. If the handle suddenly feels heavy while being turned, stop turning the handle.
- Once the setting is completed, push the handle down and lock it.
- To decrease the outlet pressure, after the pressure has been set, rotate the handle in the direction of the arrow (-). The residual air will be released from the area of the handle, due to the relief construction of the governor.
- To reset the pressure, first reduce the pressure so that it is lower than the desired pressure; then, set it to the desired pressure.

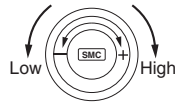

2. Setting the pressure on the air-operated type (VBA22A, 42A)

- Connect the outlet pipe of the pilot regulator for the remote control to the pilot port (P). (Refer to the diagram below.)
- Refer to the graph below for the relationship between the pilot pressure and outlet pressure.
- The AR20 and AW20 are recommended for the pilot regulator.

Pilot regulator

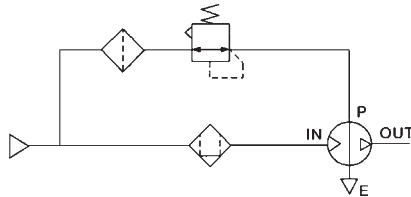

- The outlet pressure is twice the pilot pressure.
- When the inlet pressure is 0.4 MPa (58 psi):

Pilot pressure
0.2 MPa to 0.4 MPa
(29 psi to 58 psi)

Outlet pressure
0.4 MPa to 0.8 MPa
(58 psi to 116 psi)

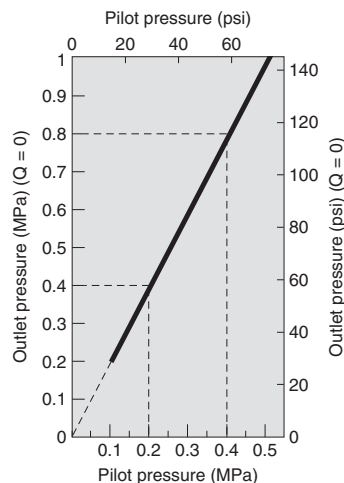

3. Draining

- If this product is used with a large amount of drainage accumulated in the filter, mist separator or tank, the drainage could flow out, leading to equipment malfunction. Therefore, drain the system once a day. If it is equipped with an auto drain, check its operation once a day.

4. Exhaust

- Exhausting time from E port may be longer for a booster regulator which is set to switch in longer hour intervals. This is not an abnormal phenomenon.

5. Maintenance

- Life expectancy varies depending on the quality of air and the operating conditions. Signs that the unit is reaching the end of its service life include the following:
 - Constant bleed from under the handle.
 - Air exhaust noise can be heard from the booster regulator at 10 to 20 second intervals even when there is no air consumption on the outlet side.
- Conduct maintenance earlier than scheduled in such cases.
- When maintenance is required, confirm the model and serial number of the booster regulator, and please contact SMC for maintenance kit.
- Conduct maintenance according to the specified maintenance procedure by individuals possessing enough knowledge and experiences in maintaining pneumatic equipment.
- The list of replacement parts and kit number are shown on page 9, and the figure shows the position of the parts.

Series VBA

Construction/Replacement Parts

VBA10A

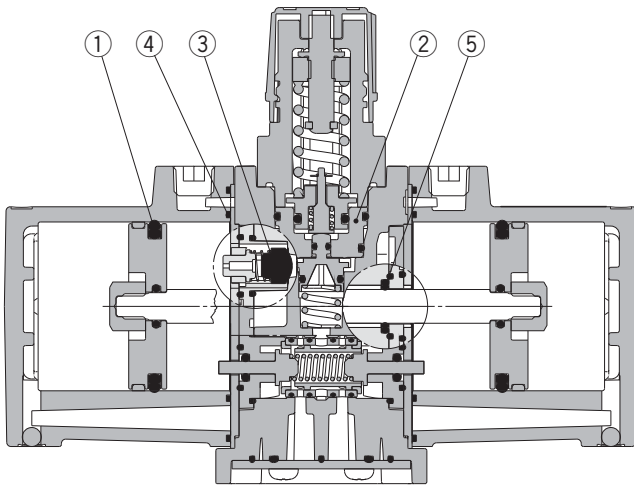

VBA11A

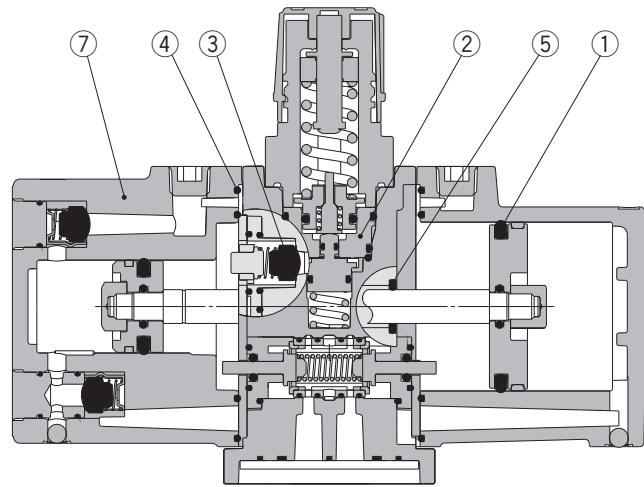

VBA20A, 22A,
VBA40A, 42A, 43A

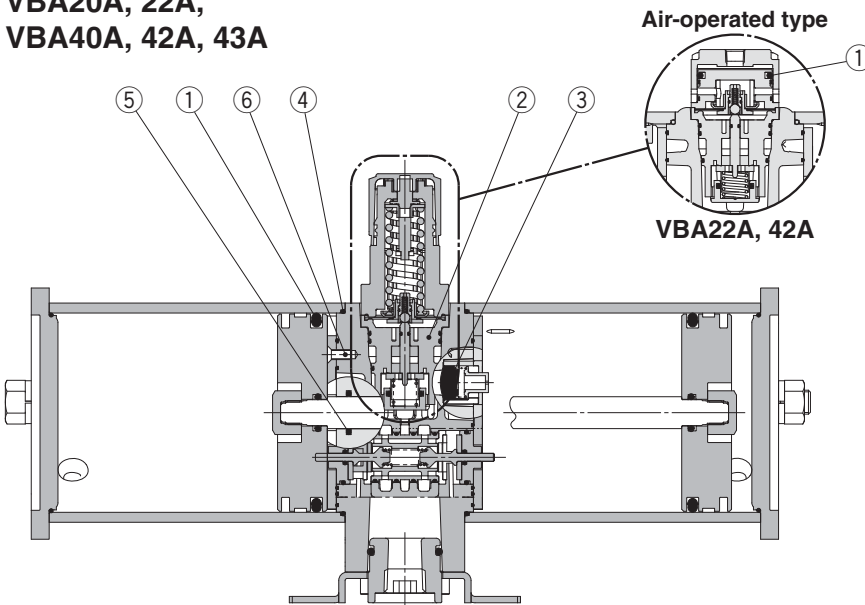

Replacement Parts/Kit No.

Place an order with the following applicable kit number.

Model	VBA10A	VBA20A	VBA40A	VBA22A	VBA42A	VBA43A	VBA11A
Kit no.	KT-VBA10A-1	KT-VBA20A-1	KT-VBA40A-1	KT-VBA22A-1	KT-VBA42A-1	KT-VBA43A-1	KT-VBA11A-20

The kit includes the parts from ① to ⑦ and a grease pack.

No.	Description	Model						
		VBA10A	VBA20A	VBA40A	VBA22A	VBA42A	VBA43A	VBA11A
1	Piston seal		2		2 large 1 small		2	1 each large and small
2	Governor assembly				1			
3	Check valve			4				2
4	Gasket				2			
5	Rod seal				1			
6	Mounting screw	—	8	12	8	12		
7	Cover C assembly							1
—	Grease pack	1		2	1	2		1

* The grease pack has 10 g (0.35 oz) of grease.

* Make sure to refer to the procedure for maintenance.

Dimensions

mm (inch)

VBA10A-02

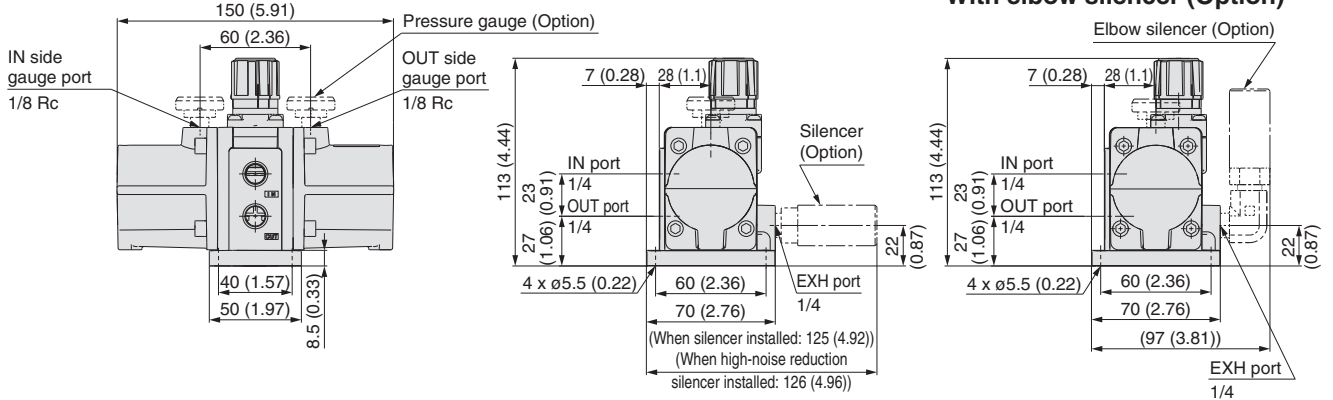

VBA11A-02

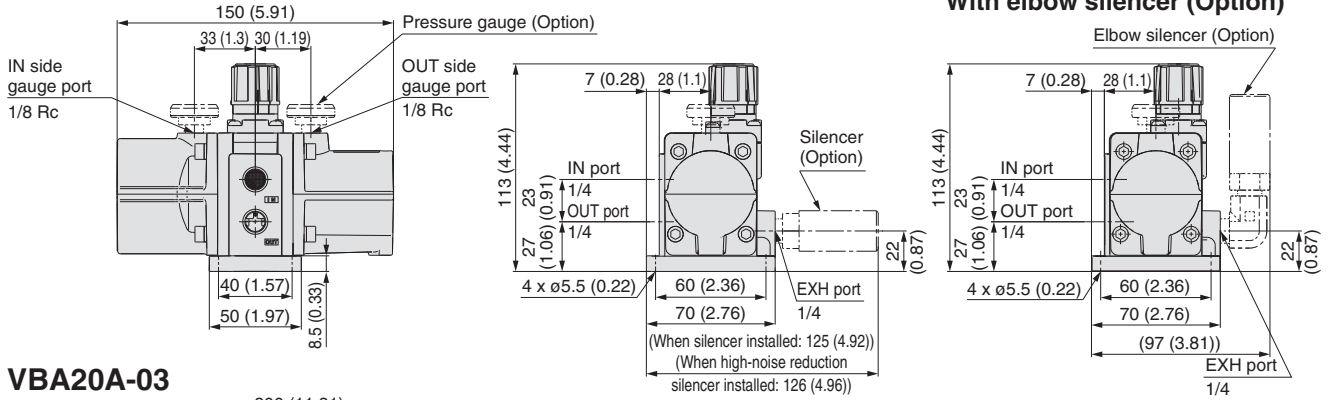

VBA20A-03

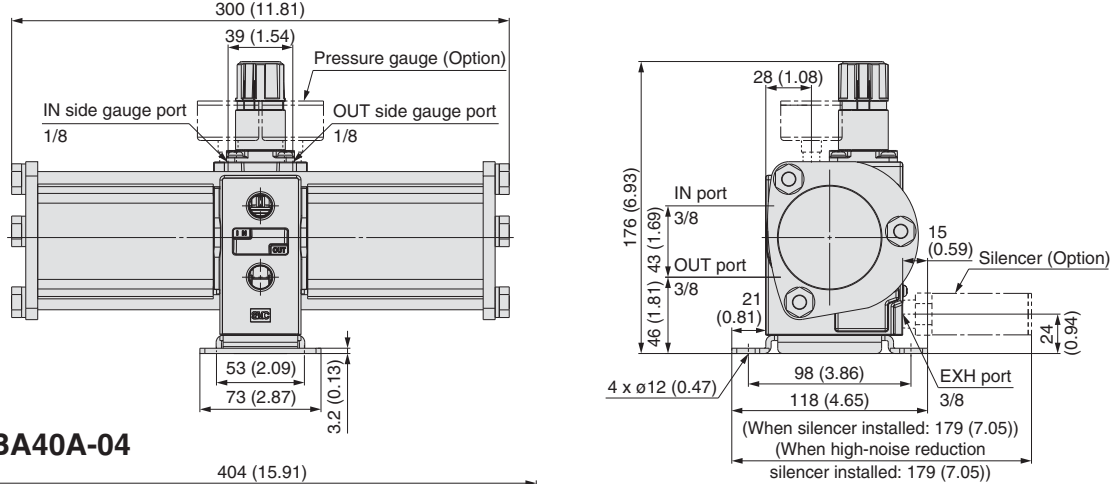

VBA40A-04

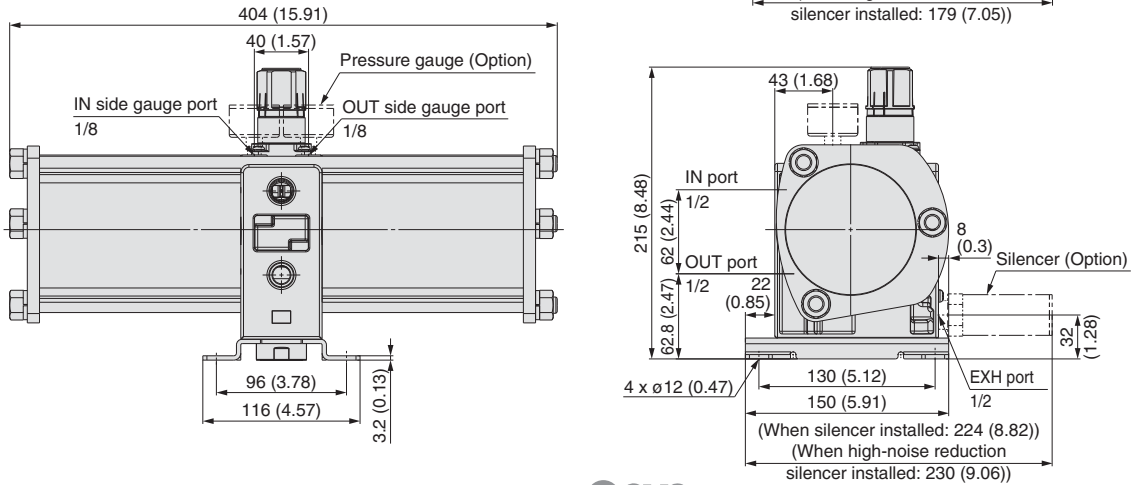

Series VBA

Dimensions

mm (inch)

VBA22A-03

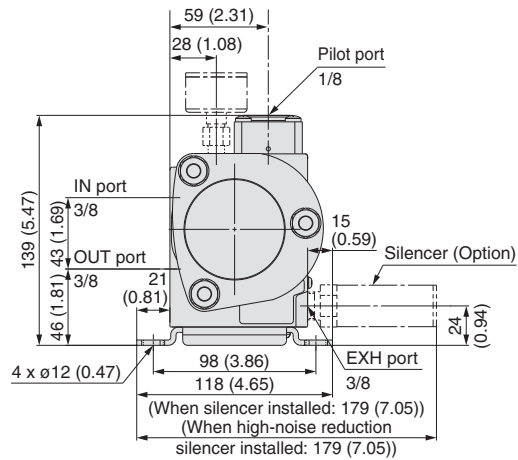
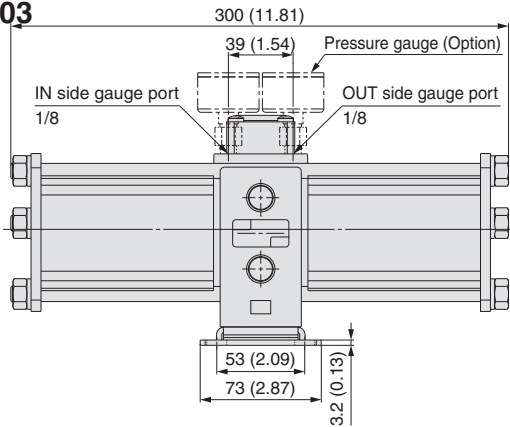

VBA42A-04

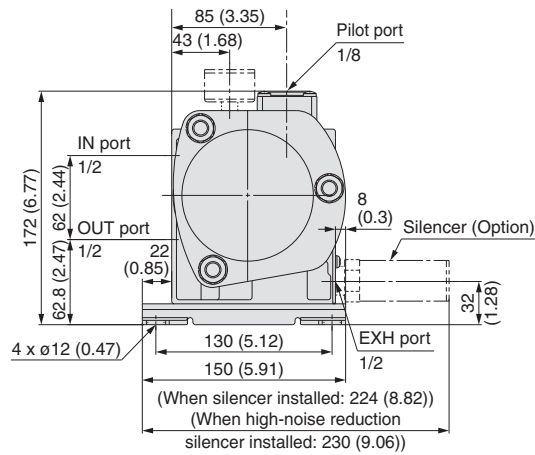
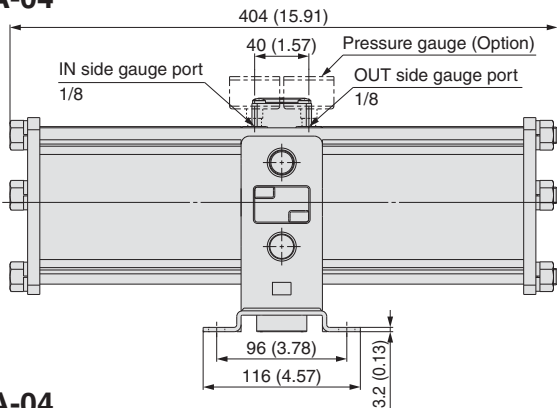

VBA43A-04

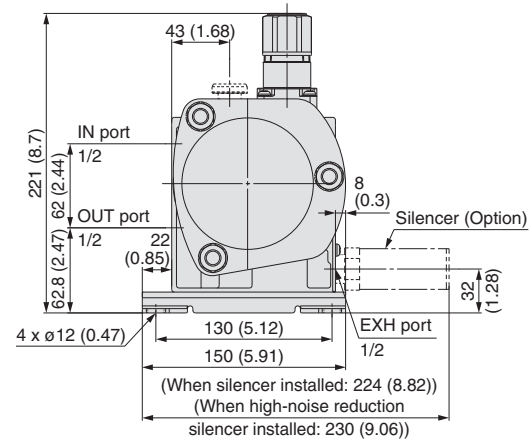
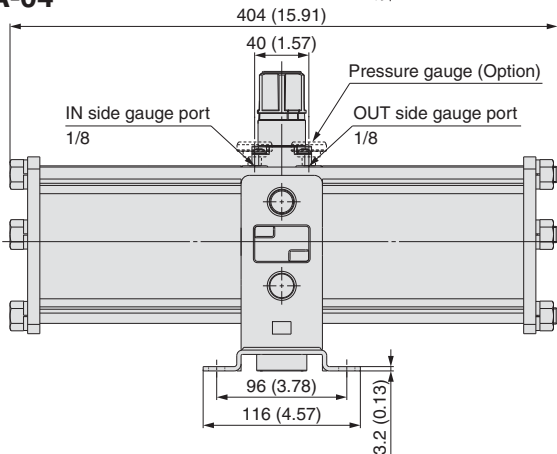

Made to Order



For detailed dimensions, specifications and lead times, please contact SMC.

1 Copper-free/Fluorine-free

The inner or outer copper parts material has been changed to stainless steel or aluminum. The fluorine resin parts has been changed to general resin.

20 — Standard model no.

• Made to Order
Copper-free/Fluorine-free

* For booster regulator with pressure gauge, please consult SMC.
* This option cannot be selected for air tank with safety valve.

2 CE explosion-proof directive (ATEX) compliant

56 — Standard model no.

• Made to Order
CE explosion-proof directive (ATEX):
Category 3GD

3 Ozone resistant

Ozone resistance is strengthened through the use of fluororubber (diaphragm) and hydrogenated NBR (valve, rod seal) for the rubber parts of the seal material.

80 — Standard model no.

• Made to Order
Ozone resistant

* Weather resistant NBR (diaphragm) and hydrogenated NBR (valve) are used for the rubber parts of the standard model.

Air Tank

Series VBAT



How to Order

- Compact connections are possible with booster regulators.
- It can be used alone as a tank.
- Tanks that are less than 6" I.D. and are outside the scope of ASME Standards Section VIII Division 1.



VBAT05A1-X11

VBAT 05 A N 1 - SV - X11

Tank inner volume

Symbol	Inner volume
05	5 L (1.3 gal.)
10	10 L (2.6 gal.)

Material

Symbol	Material
A	Carbon steel

Less than 6" I.D. tanks

Option

Symbol	Option
Nil	None ^{Note 1)}
V	Drain valve ^{Note 1)}
S	Safety valve (CE marked) [Set pressure 2 MPa (290 psi)]
SV	<ul style="list-style-type: none"> • Safety valve (CE marked) [Set pressure 2 MPa (290 psi)] • Drain valve
E ^{Note 2)}	Safety valve (ASME UV stamped) [Set pressure 2 MPa (290 psi)]
EV ^{Note 2)}	<ul style="list-style-type: none"> • Safety valve (ASME UV stamped) [Set pressure 2 MPa (290 psi)] • Drain valve

Note 1) Safety valve should be prepared by the customer.

Note 2) Sold only by SMC Corporation of America; contact for availability if needed for product that will be sold/used in the United States.

Thread type

Symbol	Thread type
Nil	Rc
N	NPT ^{Note)}

Note) Pressure for NPT thread products indicated in psi only

Model

Model	VBAT05A□1-□-X11	VBAT10A□1-□-X11
Fluid	Compressed air	
Tank capacity	5 L (1.3 gal.)	10 L (2.6 gal.)
Max. operating pressure	2.0 MPa (290 psi)	
IN port size	3/8	3/8
OUT port size	3/8	1/2
Ambient and fluid temperature	0 to 75°C (32 to 167°F)	
Weight	6.6 kg (14.6 lb)	11 kg (24.3 lb)
Material	Carbon steel	
Paint	Outside: Silver paint, Inside: Rustproof paint	

Note) Accessories and options are included in the same container.

Note) These tanks are less than 6" I.D. and are outside the scope of ASME Section VIII, Division 1.

While they should be acceptable for use in most states and municipalities, please consult with the regulatory agency in your area to determine if they are compliant with the intended application.

Options/Accessory/Part No.

Model	VBAT05A*1-□-X11	VBAT10A*1-□-X11
Accessory kit	VBAT5A-Y-3*	VBAT10A-Y-3*
Safety valve (CE marked) ^{Note 1)}	VBAT-S* [Set pressure 2 MPa (290 psi)]	
Safety valve (ASME UV stamped) ^{Note 2)}	VBAT-E* [Set pressure 2 MPa (290 psi)]	
Drain valve ^{Note 1)}	VBAT-V1*	

* "Nil" when Rc thread is selected, "N" when NPT thread is selected.

Note 1) These valves are not for North American installation and are intended for use on equipment that will be exported to Europe.

Note 2) Sold only by SMC Corporation of America; contact for availability if needed for product that will be sold/used in the United States.

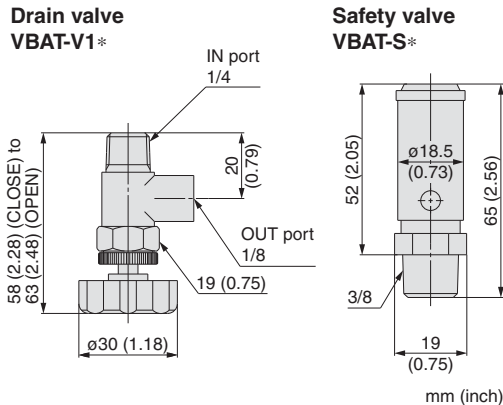

List of Air Tank for Overseas

Country/Region	Law	Exportable models	Details
EU	CE Marking Simple Pressure Vessels Directive ^{Note 2)}	VBAT05A*-SV-Q	Applicable product Self-declaration document attached (For details, consult with SMC.)
		VBAT10A*-SV-Q	
		VBAT20A*-RV-Q	
		VBAT38A*-RV-Q	

* "Nil" when Rc thread is selected, "F" when G thread is selected

Note 1) This product is not for North American installation and is intended for use on equipment that will be exported to Europe.

Note 2) Information as of August 2006

Design

⚠ Warning

1. Operating pressure

- Operate this product at or below the maximum operating pressure. If it is necessary, take appropriate safety measures to ensure that the maximum operating pressure is not exceeded.
- When the tank alone is used**
Use a pressure switch or a safety valve to make sure that the maximum operating pressure is not exceeded.

2. Connection

- Connect a filter or a mist separator to the OUT side of the tank. Because the inner surface of the tank is untreated, there is a possibility of dust flowing out to the outlet side.
- Using tank accessories, a VBA booster regulator can be connected directly in the combinations indicated below.

		Booster regulator	
		VBA1□A	VBA2□A
Air tank	VBAT05A1-X11	●	—
	VBAT10A1-X11	●	●

Selection

⚠ Caution

- Consider the operating conditions and operate this product within the specification range.
- When using the air tank with a booster valve, refer to "Sizing" on page 6 or SMC Pneumatic System Energy Saving Program.

Mounting

⚠ Caution

1. Accessories

- See the operating manual regarding combining booster regulators with older model air tanks.
- The accessories are secured by bands to the feet of the tank. Once removed, make sure not to lose them.

2. Installation

- Tank should be installed away from people. It is dangerous if the accumulated air inside the tank were to seep out.
- Do not mount the air tank on a moving part or a place with vibration.
- When connecting a booster regulator with the tank, refer to the operating manual first, which is provided with the air tank before assembling.
- Refer to the operating manual regarding mounting methods when using long bolts.
- To mount the air tank on a floor surface, use the four holes to secure the tank with bolts or anchor bolts.

Maintenance

⚠ Warning

1. Inspection

- The use of pressure vessels could lead to an unexpected accident due to external damage or internal corrosion caused by drainage. Therefore, make sure to check periodically for external damage, or the extent of internal corrosion through the port hole. An ultrasonic thickness indicator may also be used to check for any reduction in material thickness.

2. Draining

- If this product is used with a large amount of drainage, the drainage could flow out, leading to equipment malfunction or corrosion inside the tank. Therefore, drain the system once a day.

Series VBAT

Dimensions

mm (inch)

VBAT05A□1-X11 Material: Carbon steel

Connected to VBA10A, VBA11A

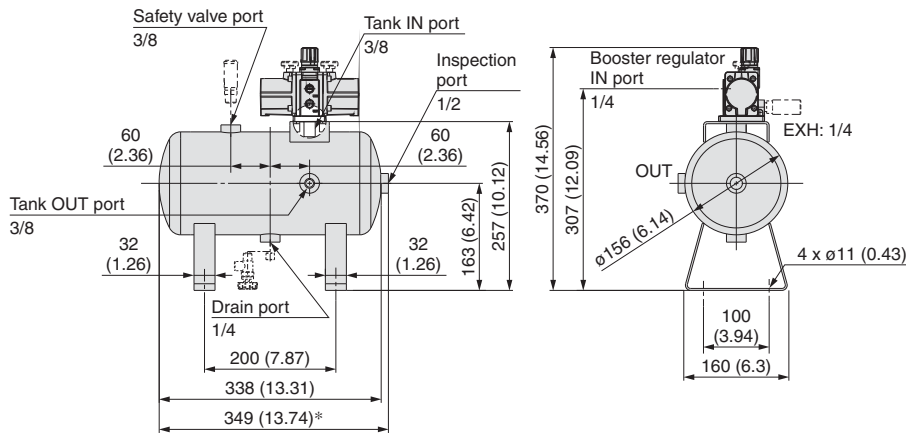

* The length may be longer than the specification if the plugs mounted on the tank are not fit to the end.

VBAT10A□1-X11 Material: Carbon steel

Connected to VBA10A, VBA11A

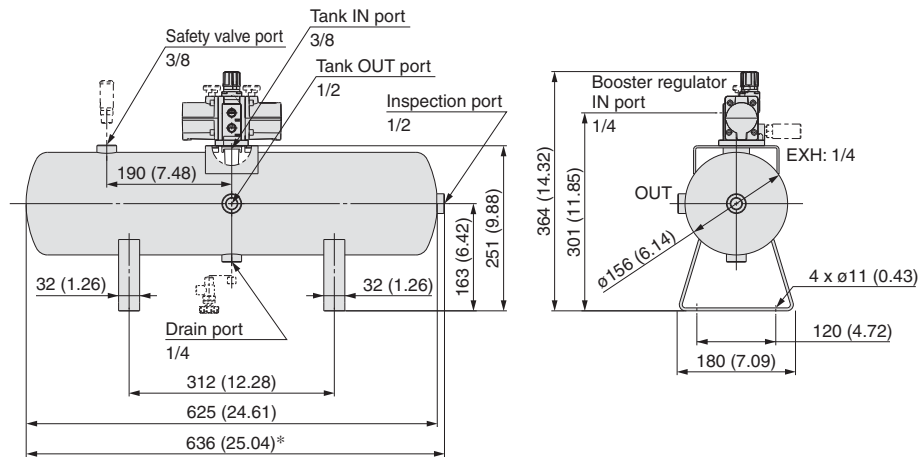

* The length may be longer than the specification if the plugs mounted on the tank are not fit to the end.

Connected to VBA20A, VBA22A

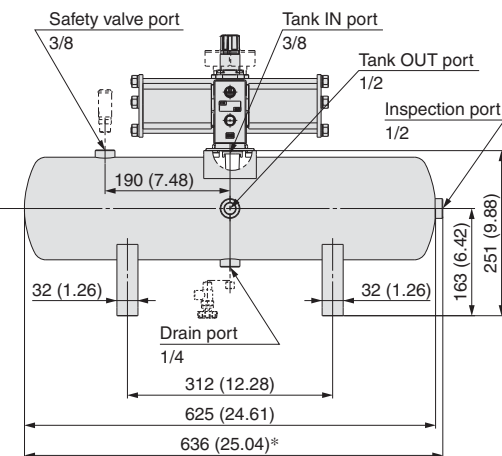

Connected to VBA22A

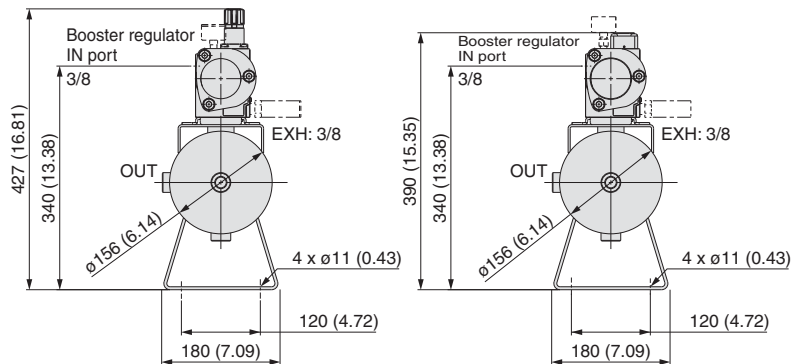



* The length may be longer than the specification if the plugs mounted on the tank are not fit to the end.

Safety Instructions

These safety instructions are intended to prevent hazardous situations and/or equipment damage. These instructions indicate the level of potential hazard with the labels of “**Caution**,” “**Warning**” or “**Danger**.” They are all important notes for safety and must be followed in addition to International Standards (ISO/IEC), American National Standards Institute (ANSI)*1) and other safety regulations.

 **Caution:** **Caution** indicates a hazard with a low level of risk which, if not avoided, could result in minor or moderate injury.

 **Warning:** **Warning** indicates a hazard with a medium level of risk which, if not avoided, could result in death or serious injury.

 **Danger:** **Danger** indicates a hazard with a high level of risk which, if not avoided, will result in death or serious injury.

*1) ISO 4414: Pneumatic fluid power – General rules relating to systems.
 ISO 4413: Hydraulic fluid power – General rules relating to systems.
 IEC 60204-1: Safety of machinery – Electrical equipment of machines. (Part 1: General requirements)
 ISO 10218-1: Manipulating industrial robots - Safety.
 ANSI / (NFPA) T2.25.1 R2: Pneumatic fluid power - Systems standard for industrial machinery.
 NFPA (Fluid) T2.24.1 R1: Hydraulic fluid power - Systems standard for stationary industrial machinery.
 NFPA 79: Electrical Standard for Industrial Machinery.
 ANSI / RIA / ISO 10218 -1: Robots for Industrial Environment - Safety Requirements - Part 1 - Robot. etc.

Warning

1. The compatibility of the product is the responsibility of the person who designs the equipment or decides its specifications.

Since the product specified here is used under various operating conditions, its compatibility with specific equipment must be decided by the person who designs the equipment or decides its specifications based on necessary analysis and test results. The expected performance and safety assurance of the equipment will be the responsibility of the person who has determined its compatibility with the product. This person should also continuously review all specifications of the product referring to its latest catalog information, with a view to giving due consideration to any possibility of equipment failure when configuring the equipment.

2. Only personnel with appropriate training should operate machinery and equipment.

The product specified here may become unsafe if handled incorrectly. The assembly, operation and maintenance of machines or equipment including our products must be performed by an operator who is appropriately trained and experienced.

3. Do not service or attempt to remove product and machinery/equipment until safety is confirmed.

1. The inspection and maintenance of machinery/equipment should only be performed after measures to prevent falling or runaway of the driven objects have been confirmed.
2. When the product is to be removed, confirm that the safety measures as mentioned above are implemented and the power from any appropriate source is cut, and read and understand the specific product precautions of all relevant products carefully.
3. Before machinery/equipment is restarted, take measures to prevent unexpected operation and malfunction.

4. Contact SMC beforehand and take special consideration of safety measures if the product is to be used in any of the following conditions.

1. Conditions and environments outside of the given specifications, or use outdoors or in a place exposed to direct sunlight.
2. Installation on equipment in conjunction with atomic energy, railways, air navigation, space, shipping, vehicles, military, medical treatment, combustion and recreation, or equipment in contact with food and beverages, emergency stop circuits, clutch and brake circuits in press applications, safety equipment or other applications unsuitable for the standard specifications described in the product catalog.
3. An application which could have negative effects on people, property, or animals requiring special safety analysis.
4. Use in an interlock circuit, which requires the provision of double interlock for possible failure by using a mechanical protective function, and periodical checks to confirm proper operation.

Caution

1. The product is provided for use in manufacturing industries.

The product herein described is basically provided for peaceful use in manufacturing industries.
 If considering using the product in other industries, consult SMC beforehand and exchange specifications or a contract if necessary.
 If anything is unclear, contact your nearest sales branch.

Limited warranty and Disclaimer/ Compliance Requirements

The product used is subject to the following “Limited warranty and Disclaimer” and “Compliance Requirements”. Read and accept them before using the product.

Limited warranty and Disclaimer

1. The warranty period of the product is 1 year in service or 1.5 years after the product is delivered.*2)
 Also, the product may have specified durability, running distance or replacement parts. Please consult your nearest sales branch.
2. For any failure or damage reported within the warranty period which is clearly our responsibility, a replacement product or necessary parts will be provided.
 This limited warranty applies only to our product independently, and not to any other damage incurred due to the failure of the product.
3. Prior to using SMC products, please read and understand the warranty terms and disclaimers noted in the specified catalog for the particular products.

*2) **Vacuum pads are excluded from this 1 year warranty.**

A vacuum pad is a consumable part, so it is warranted for a year after it is delivered. Also, even within the warranty period, the wear of a product due to the use of the vacuum pad or failure due to the deterioration of rubber material are not covered by the limited warranty.

Compliance Requirements

1. The use of SMC products with production equipment for the manufacture of weapons of mass destruction (WMD) or any other weapon is strictly prohibited.
2. The exports of SMC products or technology from one country to another are governed by the relevant security laws and regulations of the countries involved in the transaction. Prior to the shipment of a SMC product to another country, assure that all local rules governing that export are known and followed.

Safety Instructions

Be sure to read “Handling Precautions for SMC Products” (M-E03-3) before using.

Global Manufacturing, Distribution and Service Network

Worldwide Subsidiaries

North & South America

- U.S.A. SMC Corporation of America
- CANADA SMC Pneumatics (Canada) Ltd.
- MEXICO SMC Corporation(México), S.A. de C.V.
- BRAZIL SMC Pneumáticos do Brasil Ltda.
- CHILE SMC Pneumatics (Chile) S.A.
- COLOMBIA SMC Colombia Sucursal de SMC Chile S.A.
- ARGENTINA SMC Argentina S.A.
- BOLIVIA SMC Pneumatics Bolivia S.r.l.
- VENEZUELA SMC Neumatica Venezuela S.A.
- PERU (Distributor) IMPECO Automatización Industrial S.A.C.
- ECUADOR (Distributor) ASSISTECH CIA. LTDA.

Asia/Oceania

- CHINA SMC(China)Co.,Ltd.
- CHINA SMC Pneumatics (Guangzhou) Ltd.
- HONG KONG SMC Pneumatics(Hong Kong)Ltd.
- TAIWAN SMC Pneumatics(Taiwan)Co.,Ltd.
- KOREA SMC Pneumatics Korea Co., Ltd.
- SINGAPORE SMC Pneumatics(S.E.A.)Pte.Ltd.
- MALAYSIA SMC Pneumatics(S.E.A.)Sdn.Bhd.
- THAILAND SMC (Thailand) Ltd.
- PHILIPPINES Shoketsu SMC Corporation
- INDIA SMC Pneumatics(India)Pvt.Ltd.
- ISRAEL (Distributor) Baccara Geva A.C.S. Ltd.
- INDONESIA (Distributor) PT. Sinar Mutiara Cemerlang
- VIETNAM (Distributor) Dy Dan Trading Co.,Ltd.
- PAKISTAN (Distributor) Jubilee Corporation

Asia/Oceania

- SRI LANKA (Distributor) Electro-Serv(Pvt.)Ltd.
- IRAN (Distributor) Abzarchian Co. Ltd.
- U.A.E. (Distributor) Machinery People Trading Co. L.L.C.
- KUWAIT (Distributor) Esco Kuwait Equip & Petroleum App. Est.
- SAUDI ARABIA (Distributor) Assaggaff Trading Est.
- BAHRAIN (Distributor) Mohammed Jalal & Sons W.L.L. Technical & Automative Services
- SYRIA (Distributor) Miak Corporation
- JORDAN (Distributor) Atafawok Trading Est.
- BANGLADESH (Distributor) Chemie International
- AUSTRALIA SMC Pneumatics(Australia)Pty.Ltd.
- NEW ZEALAND SMC Pneumatics(N.Z.)Ltd.
- JAPAN SMC Corporation

Europe/Africa

- GERMANY SMC Pneumatik GmbH
- SWITZERLAND SMC Pneumatik AG
- U.K. SMC Pneumatics (U.K.) Ltd.
- FRANCE SMC Pneumatique SA
- SPAIN / PORTUGAL SMC España S.A.
- ITALY SMC Italia S.p.A.
- GREECE SMC HELLAS E.P.E
- IRELAND SMC Pneumatics (Ireland) Ltd.
- NETHERLANDS (Associated company) SMC Pneumatics BV
- BELGIUM (Associated company) SMC Pneumatics N.V./S.A.
- DENMARK SMC Pneumatik A/S
- AUSTRIA SMC Pneumatik GmbH (Austria)

Europe/Africa

- CZECH REPUBLIC SMC Industrial Automation CZ s.r.o.
- HUNGARY SMC Hungary Ipari Automatizálási Kft.
- POLAND SMC Industrial Automation Polska Sp. z o.o.
- SLOVAKIA SMC Priemyselná Automatizácia Spol s.r.o.
- SLOVENIA SMC Industrijska Avtomatika d.o.o.
- BULGARIA SMC Industrial Automation Bulgaria EOOD
- CROATIA SMC Industrijska Automatika d.o.o.
- BOSNIA AND HERZEGOVINA(Distributor) A.M. Pneumatik d.o.o.
- SERBIA(Distributor) Best Pneumatics d.o.o.
- UKRAINE(Distributor) PNEUMOTEC Corp.
- FINLAND SMC Pneumatics Finland Oy
- NORWAY SMC Pneumatics Norway AS
- SWEDEN SMC Pneumatics Sweden AB
- ESTONIA SMC Pneumatics Estonia Oü
- LATVIA SMC Pneumatics Latvia SIA
- LITHUANIA(LIETUVA) UAB "SMC Pneumatics"
- ROMANIA SMC Romania S.r.l.
- RUSSIA SMC Pneumatik LLC.
- KAZAKHSTAN SMC Kazakhstan, LLC.
- TURKEY (Distributor) Entek Pnömatik Sanayi ve. Ticaret Şirketi
- MOROCCO (Distributor) Soraflex
- TUNISIA (Distributor) Byms
- EGYPT (Distributor) Saadani Trading & Industrial Services
- NIGERIA (Distributor) Faraday Engineering Company Ltd.
- SOUTH AFRICA (Distributor) Hyflo Southern Africa (Pty.) Ltd.

U.S. & Canadian Sales Offices

WEST

- Austin
- Dallas
- Los Angeles
- Phoenix
- Portland
- San Francisco
- Vancouver

EAST

- Atlanta
- Birmingham
- Boston
- Charlotte
- Nashville
- New Jersey
- Richmond
- Rochester
- Tampa
- Montreal

CENTRAL

- Chicago
- Cincinnati
- Cleveland
- Detroit
- Indianapolis
- Milwaukee
- Minneapolis
- St. Louis
- Toronto
- Windsor

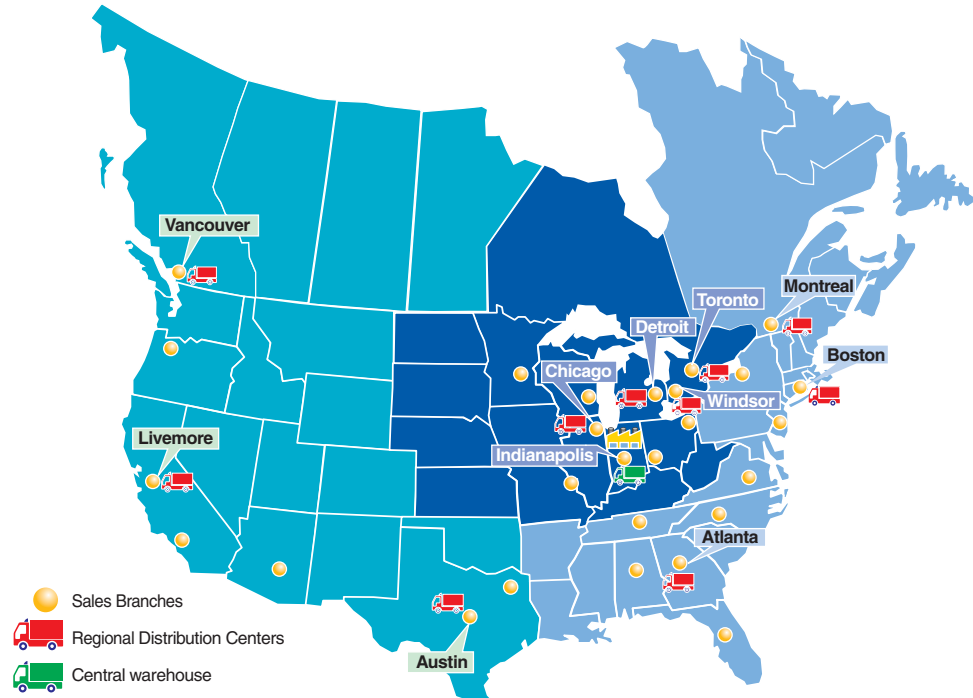

- Sales Branches
- Regional Distribution Centers
- Central warehouse

SMC Corporation of America
 10100 SMC Blvd., Noblesville, IN 46060
www.smcusa.com
SMC Pneumatics (Canada) Ltd.
www.pneumatics.ca
(800) SMC.SMC1 (762-7621)
 e-mail: sales@smcusa.com
 For International inquires: www.smcworld.com

