

Floating Pipe Type Oil Cooler

HOW Series

Water Cooled: Copper Particle Type

Large heat transfer area

The porous nature of the metal particles welded to the outer surface of the heat transfer pipes provide several times the heat transfer area of fin tube configurations.

High heat conductivity

The highly heat-conductive metal particles are firmly welded, so they provide effective cooling even when attached to a surface separated from the heat transfer pipes.

Compact design requiring less installation space

The compact design is only 1/2 to 1/5 the size of current oil coolers. Installation requires very little space.

High heat exchange effectiveness due to turbulence

The layer of metal particles reliably generates turbulence by agitating the fluid, resulting in effective cooling without unevenness.

Minimal pressure loss

The single-baffle structure increases the fluid path area. The metal particles are 2 mm in diameter, so they produce little pressure loss and will not create clogging that degrades performance.

Simple structure

The single baffle is welded to the metal particle layer for increased rigidity, a design that eliminates problems that previously tended to occur at the joints between the heat transfer pipes and baffles in current oil coolers.

Easy maintenance

The floating pipe type makes interior cleaning and inspection easy. The compact pipe bundle makes for easy handling.

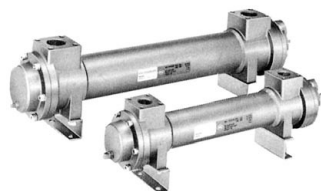

Specifications

Max. operating pressure	(Oil and Water sides) 1.0 MPa
Proof pressure	(Oil and Water sides) 1.5 MPa
Fluid temperature	Oil side: Max. 100°C/Water side: Max. 50°C
Cooling water	Industrial water, Tap water
Fluid cooled	General petroleum-based hydraulic fluid, Lubricating oil ^{Note 1)}
Heat transfer medium	Copper tube and copper particles
Connection	Threaded ^{Note 2)}

Note 1) Not suitable for use with non-flammable fluid (water-glycol) or phosphoric ester hydraulic fluid.
 Note 2) Thread connection is standard for the oil side, but flange connection is possible using a (custom) companion flange.

Model

Model	Heat transfer area (inside pipe) (m ²)	Heat exchange volume (kW)	Oil side		Cooling water side		Weight (kg)
			Flow rate range (L/min)	Flow rate (L/min)	Flow rate (L/min)	Pressure drop (MPa)	
HOW008M-06	0.084	6	20 to 130	25	0.02	7	
HOW013M-06	0.13	8.5	30 to 160	25	0.02	8	
HOW021M-12	0.21	14	35 to 200	65	0.03	14	
HOW032M-12	0.32	21	40 to 250	65	0.03	18	
HOW050M-12	0.50	30	50 to 300	65	0.03	24	
HOW075M-14	0.75	52	60 to 400	100	0.05	42	

Note 1) Conditions: Turbine oil Class 1 (ISO VG32), oil outlet temperature 50°C, water inlet temperature 30°C

Note 2) Increasing the cooling water flow volume to greater than the rated flow volume will increase the heat transfer and provide better cooling, but should be avoided as the increased flow speed within the pipe can cause corrosion.

How to Order

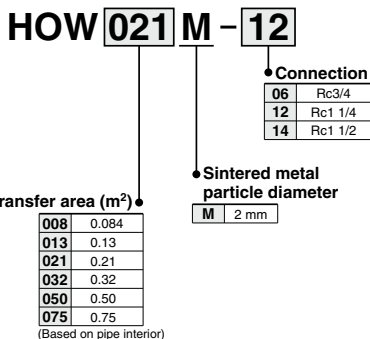

HOW Series

Model Selection

To select the appropriate model for your application, use the data at right and follow the steps below. (Note that Data (A) through Data (D) are listed in the HOW series section.)

Item	Fluid cooled	Cooling water
Type (brand)	Turbine oil Class 1 (VG56)	—
Flow rate	130 L/min	(47) L/min
Temperature	Inlet	25°C
	Outlet	50°C
Heat exchange volume	15 kW	

Step (A): No Cooling Water Flow Rate Specified

- From Data (A), calculate the oil type–heat volume correction coefficient.
— Example: $A = 0.97$
- From Data (B), calculate the water temperature–heat volume correction coefficient.
— Example: $B = 1.3$
- Using the correction coefficients obtained in (1) and (2), calculate the converted heat exchange volume.
— Example: $Q = \frac{15}{0.97 \times 1.3} = 11.9 \text{ kW}$
- Select the appropriate model from the model performance graph.
— Example: Oil outlet temperature 50°C, selected model **HOW021M**
In this case, the oil pressure drop can be calculated as follows.
- From the model performance graph, determine the oil pressure drop.
— Example: $\Delta P = 0.06 \text{ MPa}$
- From Data (D), calculate the oil type–pressure drop correction coefficient.
— Example: $D = 1.4$
- Using (5) and (6), calculate the corrected oil pressure drop.
— Example: $\Delta P = 0.6 \times 1.4 = 0.084 \text{ MPa}$

(Result) Model: HOW021M, Oil pressure drop: $\Delta P = 0.084 \text{ MPa}$,
Rated water volume: 65 L/min

Step (B): Cooling Water Flow Rate Specified

- From Data (A), calculate the oil type–heat volume correction coefficient.
— Example: $A = 0.97$
- From Data (B), calculate the water temperature–heat volume correction coefficient.
— Example: $B = 1.3$
- From the model performance graph, locate the intersection of the oil flow rate and heat exchange volume lines to make a provisional model selection. Note that the rated water volume for the selected model can be determined from the specifications.
— Oil outlet temperature 50°C, provisional model selection HOW021M, rated water volume 65 L/min.
- Divide the actual water volume by the rated water volume from (3). If the calculated water volume is 1 or greater, treat it as 1.
— Example: $\frac{47}{65} = 0.72$
- From Data (C), calculate the water volume–heat volume correction coefficient.
— Example: $C = 0.85$
- Using the correction coefficients obtained in (1), (2), and (5), calculate the converted heat exchange volume.
— Example: $Q = \frac{15}{0.97 \times 1.3 \times 0.85} = 14 \text{ kW}$
- Select the appropriate model from the model performance graph.
— Example: Oil outlet temperature 50°C, selected model **HOW021M**
In this case, the oil pressure drop can be calculated as follows.
- From the model performance graph, determine the oil pressure drop.
— Example: $\Delta P = 0.06 \text{ MPa}$
- From Data (D), calculate the oil type–pressure drop correction coefficient.
— Example: $D = 1.4$
- Using (8) and (9), calculate the corrected oil pressure drop.
— Example: $\Delta P = 0.6 \times 1.4 = 0.084 \text{ MPa}$

(Result) Model: HOW021M, Oil pressure drop: $\Delta P = 0.084 \text{ MPa}$,
Cooling water volume: 47 L/min

Model Performance Graph ①: Oil Outlet Temperature 40°C

Conditions Oil outlet temperature: 40°C
Water inlet temperature: 30°C
Fluid: Turbine oil Class 1 (ISO VG32)
Oil side pressure drop: 0.01, 0.03, 0.05, 0.1 MPa indicated

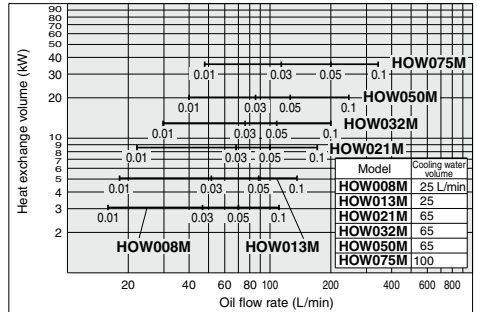

Model performance values include an allowance (approx. 25%) for water deposits.

Model Performance Graph ②: Oil Outlet Temperature 50°C

Conditions Oil outlet temperature: 50°C
Water inlet temperature: 30°C
Fluid: Turbine oil Class 1 (ISO VG32)
Oil side pressure drop: 0.01, 0.03, 0.05, 0.1 MPa indicated

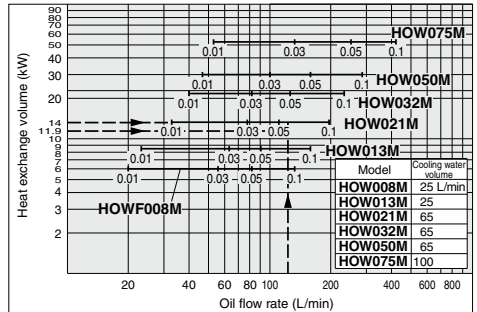

Model performance values include an allowance (approx. 25%) for water deposits.

Model Performance Graph ③: Oil Outlet Temperature 60°C

Conditions Oil outlet temperature: 60°C
Water inlet temperature: 30°C
Fluid: Turbine oil Class 1 (ISO VG32)
Oil side pressure drop: 0.01, 0.03, 0.05, 0.1 MPa indicated

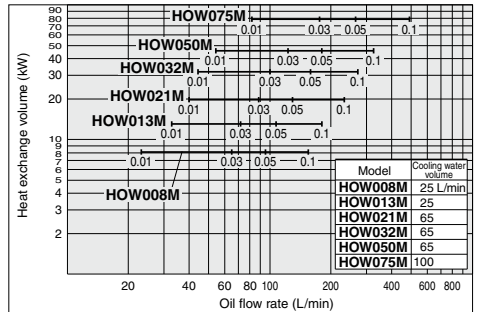

Model performance values include an allowance (approx. 25%) for water deposits.

Construction

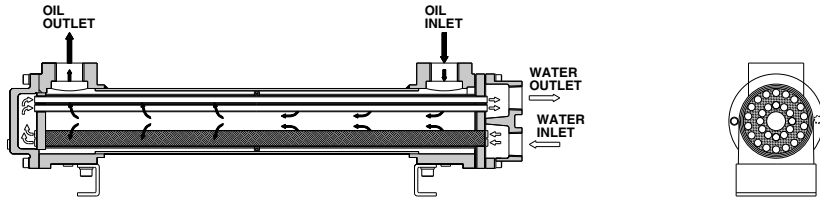

Construction description

The HOW series employs a multi-pipe design with the heat transfer pipes arranged in a circular pattern. The area between the pipes is filled with porous metal particles. Cooling water flows through the heat transfer pipes. Fluid flows in through the inlet on the side of the shell and passes into the metal particle layer outside the heat transfer pipes, finally reaching the open cavity in the center. It then flows axially through the center cavity, once again passes through the metal particle layer, and flows out through the outlet. The cooling water inlet and outlet may be reversed, and the oil inlet and outlet may be reversed as well. It is not possible to switch the cooling water and oil flow paths, however.

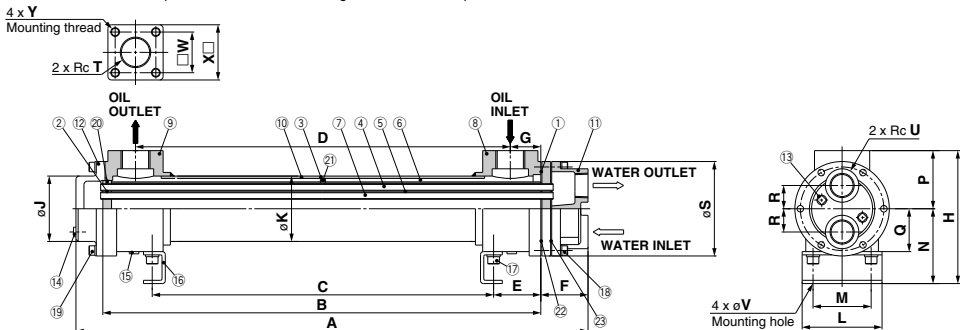

Model	A	B	C	D	E	F	G	H	øJ	øK	L	M	N	P	Q	R	øS	T	U	øV	□W	□X	Y (Mounting thread)
HOW008M-06	493	400	300	336	50	58	32	149	64	73	90	60	87	62	47	25	100	3/4	1/2	10	40	56	M8 x P1.25 x depth 14
HOW013M-06	693	600	500	536	50	58	32	149	64	73	90	60	87	62	47	25	100	3/4	1/2	10	40	56	M8 x P1.25 x depth 14
HOW021M-12	505	400	270	316	65	65	42	184	90	90	110	80	104	80	59	32	130	1 1/4	1	12	56	76	M12 x P1.75 x depth 20
HOW032M-12	705	600	470	516	65	65	42	184	90	90	110	80	104	80	59	32	130	1 1/4	1	12	56	76	M12 x P1.75 x depth 20
HOW050M-12	1055	950	820	866	65	65	42	184	90	90	110	80	104	80	59	32	130	1 1/4	1	12	56	76	M12 x P1.75 x depth 20
HOW075M-14	1077	950	780	842	85	77	54	230	118	120	150	100	130	100	75	40	168	1 1/2	1 1/4	14	65	92	M16 x P2 x depth 25

Component Parts

No.	Description	Material	Quantity
①	Tube sheet A	SS400	1
②	Tube sheet B	SS400	1
③	Baffle	SS400	1
④	Heat transfer pipes	C1220T	—
⑤	Metal particle layer	Cu	—
⑥	Metal particle cover A	Stainless steel 304	2
⑦	Metal particle cover B	Stainless steel 304	1
⑧	Shell flange A	AC4C	1
⑨	Shell flange B	AC4C	1
⑩	Shell pipe	A6063T	1
⑪	Water chamber cover A	FC200	1
⑫	Water chamber cover B	FC200	1

No.	Description	Material	Quantity
⑬	Corrosion-resistant plug	Zn, FCMB	2
⑭	Water drain plug	FCMB	1
⑮	Oil drain plug	FCMB	2
⑯	Foot	SS400	2
⑰	Foot bolt	S20C	4
⑱	Cap bolt	SCM3	6
⑲	Cap bolt	SCM3	6
⑳	O-ring A	NBR	1
㉑	O-ring B	NBR	1
㉒	Seal A	V#6500	1
㉓	Seal B	V#6500	1

• If you are unsure which model is suitable, please refer to the items at right and contact SMC.

Application			
Heat exchange volume		kW	
Item	Fluid to be cooled	Cooling water	
Type (brand)			
Flow rate		L/min	L/min
Temperature	Inlet	°C	°C
	Outlet	°C	—
Allowable pressure drop		MPa	MPa
Max. operating pressure		MPa	MPa
Property values	Weight volume ratio	kg/cm ³	—
	Specific heat	kW/kg°C	—
	Viscosity	mm ² /s	—
If hydraulic fluid, hydraulic motor output		kW	—



HOW/HOWF Series

Specific Product Precautions

Be sure to read this before handling the products.
Refer to back page 50 for Safety Instructions.

Design

Caution

1. Do not use at a pressure that exceeds the operating pressure range.
2. Do not use at a temperature that exceeds the operating temperature range.
3. **Fluid**
Do not use the product with gases.
4. **Fatigue damage**
Under the following conditions, special measures are required:
 - 1) If the product will be subjected to pressure surges.
 - 2) If the product is not mounted securely and will be subject to friction or vibrations.
5. **Corrosion**
The product may corrode depending on usage conditions and environment.

Selection

Warning

1. When selecting products, carefully consider the usage purpose, the required specifications, and the usage conditions (fluid, pressure, flow rate, temperature, environment), and ensure that the specification range is not exceeded.
2. The fluid used must not be heated to the boiling point.
3. Do not use the product with air or other gases under any circumstances.
4. Do not use the product in circumstances where it will be exposed to pressure that exceeds 1 MPa, such as with a water hammer or surge pressure.

Fluid

Warning

1. Use tap water or industrial water as cooling water.
Do not use seawater.
2. Do not use for cooling chemicals or food products.

Piping

Caution

1. Make sure to allow sufficient space for maintenance when installing and piping.
2. **Connections**
Make sure no cutting chips from pipe threads or sealing material gets inside the piping. If sealant tape is used, leave 1.5 to 2 thread ridges exposed at the end of the male thread.
3. **Filter installation**
Install #100 μm filters into the inlet pipes of the oil cooler on both the oil and cooling water sides.
4. **The cooling water inlet and outlet may be reversed, and the oil inlet and outlet may be reversed as well. It is not possible to switch the cooling water and oil flow paths, however.**

Operating Environment

Caution

1. If the product is used in an environment or location conducive to corrosion, discoloration or deterioration due to corrosion may occur.
2. Fatigue damage may occur if the product is used in a location subject to vibrations or impacts.

Maintenance

Caution

1. Wash out the cooling water side once a year.