

Oil Filter

FH150 Series



Compact and lightweight

The compact and lightweight design employs an aluminum alloy cover.

Easy maintenance

The element slides into place, making it easy to install and remove.

Clogging sensor

The filter can be fitted with a differential pressure indicator (reset type) or differential pressure indication switch (visual combined, non-reset type).



Specifications

Fluid		Hydraulic fluid
Operating pressure		Max. 1 MPa
Operating temperature		Max. 80°C
Main material	Cover	Aluminum die-cast
	Case	Steel plate
	O-ring	NBR or FKM ^{Note)}
Element	Material	Paper
	Nominal filtration	5, 10, 20 μm
	Differential pressure resistance	0.6 MPa
Differential pressure indicator operating pressure (Element replacement differential pressure)		0.13 MPa

Note) The material of the O-rings and seals differs depending on the hydraulic fluid used.
Petroleum, Water-glycol, Emulsion: NBR; Phosphoric ester: FKM

Model/Rated Flow Rate

Model	Port size (Rc)	Rated flow rate (L/min)
FH150-02	1/4	5
FH150-03	3/8	10
FH150-04	1/2	20



Accessory/Option

Description	Part no.	Note
Differential pressure indicator	CB-50H	Petroleum, Water-glycol, Emulsion
	CB-50H-V	Phosphoric ester
Differential pressure indication switch (N.C. and N.O. common)	CB-51H	Petroleum, Water-glycol, Emulsion
	CB-51H-V	Phosphoric ester
Blanking cap (for differential pressure indication part)	AG-12H	Petroleum
	AG-12H-W	Water-glycol, Emulsion
	AG-12H-V	Phosphoric ester
Bracket	B44P	—

How to Order

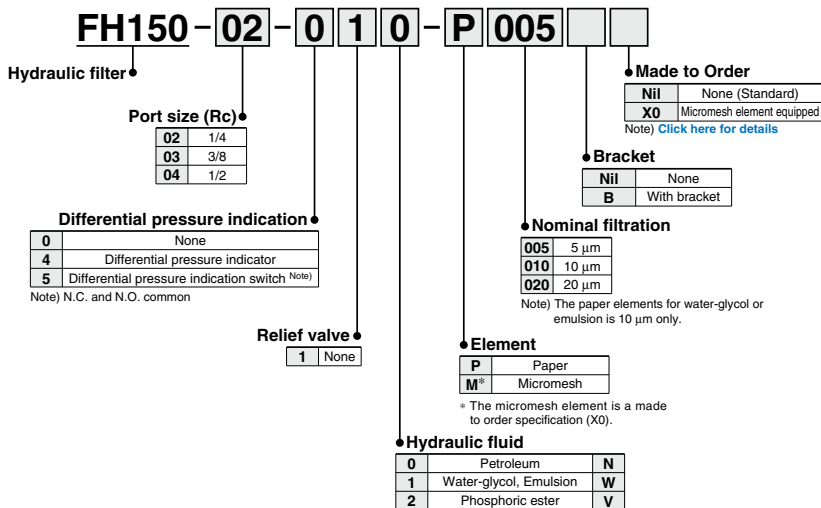

Note) N, W and V refer to the hydraulic fluid symbol indicated at the end of the element part number.

Replacement Element Part No. (Including O-ring for element)

Model	5 μm	10 μm	20 μm	Element size
FH150-02	EP910-005N	EP910-010N	EP910-020N	ø55 x 90
FH150-03				
FH150-04				

Note 1) The symbol at the end of the element part no. indicates the hydraulic fluid type.

N: Petroleum, V: Phosphoric ester, W: Water-glycol, Emulsion (10 μm only)

Note 2) Refer to page 528 for micromesh elements.

Note 3) Above elements require one element per filter.

Construction/Seal List

Oil filter

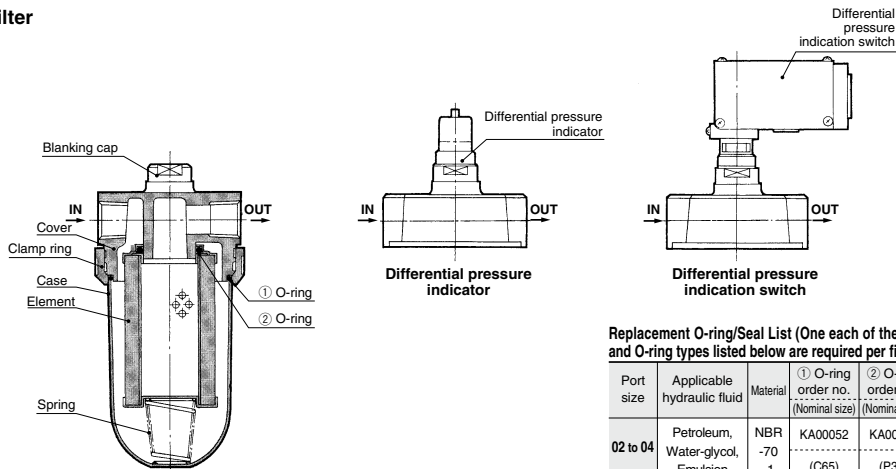

Replacement O-ring/Seal List (One each of the seal and O-ring types listed below are required per filter.)

Port size	Applicable hydraulic fluid	Material	① O-ring order no. (Nominal size)	② O-ring order no. (Nominal size)
02 to 04	Petroleum, Water-glycol, Emulsion	NBR	KA00052	KA00471
		-70	(C65)	(P30)
02 to 04	Phosphoric ester	FKM	KA01174	KA00104
		-70	(C65)	(P30)

Note) The material and nominal size notations are based on JISB2401.

Flow Rate Characteristics

FH150-02 to 04

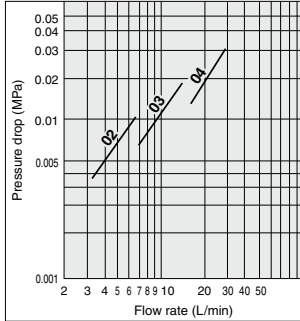

Conditions Fluid: Turbine oil Class 2 VG56
 Measured pressure: 1 MPa
 Viscosity: 45 mm²/s
 Filter material: Paper
 Nominal filtration: 10 μm

Differential Pressure Indication

Two indication methods are available: differential pressure indicator and differential pressure indication switch. These can be mounted on all filter models.

■ Differential pressure indicator

- Operating pressure—0.13 MPa
- Once a value is displayed, it will continue to be displayed until reset, even if the pump is stopped. (Reset type)
- Perform element replacement when the red ring floats up and covers the entire view port.

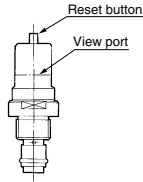

■ Differential pressure indication switch

- Operating pressure—0.13 MPa
- When a value has been displayed, it will be automatically reset when the pump is stopped. (Non-reset type)
- This is a visual dual-purpose. Perform element replacement when the switch has actuated (when the red ring floats up and covers the entire view port).
- N.C. and N.O. common

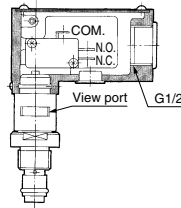

* Refer to page 529 for "Microswitch for differential pressure indication switch".

Handling Precautions

① Mounting

- Confirm IN and OUT before mounting. Then connect so that the case is oriented downward. For maintenance, make sure to provide sufficient space above the filter for removing the element.

② Operation

- The hydraulic fluid used becomes high viscosity when the temperature is low during the winter, etc., and the differential pressure indicator or the switch may activate. If this occurs, wait until the oil temperature rises by a warm-up operation, then check if this is caused by clogging.
- Once the differential pressure indicator is actuated, the indication continues to be displayed until the indicator is reset (by depressing the reset button), even if the pump stops operating.
- Reset after replacing the element and restarting operation, or after normal operation starts in cold weather such as during winter.

- When using a differential pressure indication switch and if a filter clogged signal is incorporated into the sequence circuit of the machine, make sure to design the system so the filter clogged signal does not operate until normal operation starts.

③ Element replacement

- When the pressure difference reaches 0.13 MPa during operation (actuating the differential pressure indicator), stop operation and replace the element.
- When replacing the element, drain the fluid from the case. Also, check the O-rings and replace them if they are damaged.

④ Other

- Refer to the operating manual regarding the tightening torque for clamping ring. Use a commercially available hook wrench (applicable sizes 80 to 85 mm) for tightening and removing clamping rings.

FH □

HOW □

FH150 Series

Dimensions

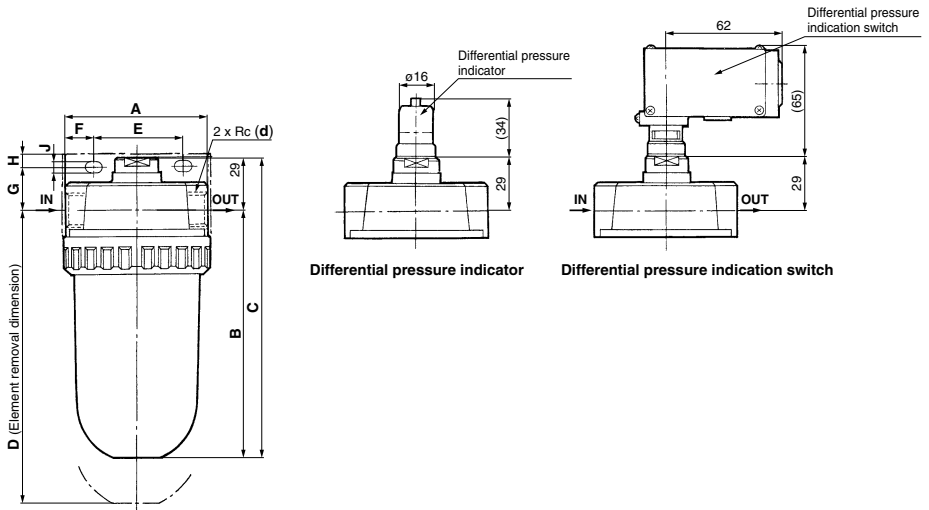

											(mm)
Model	d	A	B	C	D	E	F	G	H	J	Weight (kg)
FH150-02	1/4	80	168.5	197.5	259.5	50	15	25	7	6.5	0.7
FH150-03	3/8										
FH150-04	1/2										

(1) Contact specifications

Table 1 Contact specifications

Item	Specifications
Inrush current	Max. 15 A
Minimum applicable load	5 VDC 160 mA

(2) Rating

Table 2 Rating

Rated voltage	Resistance load
250 VAC	5 A

(3) Other performance

Table 3 Other specifications

Item	Specifications	
Insulation resistance	100 MΩ or more (Measured by 500 VDC, insulation resistance tester.)	
Contact resistance	30 mΩ or less	
Withstand voltage	Between terminals with the same pole.	1,000 VAC 50/60 Hz 1 min
	Between charged metal part and ground	1,500 VAC 50/60 Hz 1 min
	Between each terminal and non-charged metal part	1,500 VAC 50/60 Hz 1 min

(4) Electric circuit

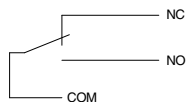

(N.C. and N.O. common)

Precautions

1. Connect desired wiring to the micro switch indication symbols 1 (COM.), 2 (N.C.), and 3 (N.O.).
2. When a protection mechanism is required, take appropriate considerations on the electric circuit since the micro switch is a type of non-reset.

(5) Terminal type

Soldering terminal