

# Compact Regulator

## Series ARX20

2.0 MPa compatible, piston type compact regulator



- Compatible with inlet supply pressure of 2.0 MPa
- Compact type (face to face dimensions 35 mm, overall length 80 mm)
- Employs a handle shape for easy operation
- Ideal for discharge pressure adjustment on a small compressor
- Piston type**
- Ideal for pressure adjustment of air blowing applications
- 3 out ports for convenient use

ARJ

AR425  
to 935

**ARX**

AMR

ARM

ARP

IR

IRV

VEX

SRH

SRP

SRF

VCHR

ITV

IC

ITVX

PVQ

VEF  
VEP

VER

VEA

VY1

VBA  
VBAT

AP100

# Compact Regulator Series ARX20

## How to Order

ARX2 0 — 01

Regulator for 2 MPa

Regulating pressure range

0	0.05 to 0.85 MPa
1 Note 1)	0.05 to 0.30 MPa

Thread type

Nll	Rc
N	NPT
F	G

Port size

01	1/8
02	1/4

Option

Nll	None		
B	Bracket	1348112	
G	Pressure gauge Note 2)	ARX20-Nll F <input type="checkbox"/>	G36-10-01
		ARX21-Nll F <input type="checkbox"/>	G46-10-02
	ARX20-N <input type="checkbox"/>		G36-4-01
			G46-4-02
P	Panel nut	ARX20-N <input type="checkbox"/>	G36-P10-N01
		ARX21-N <input type="checkbox"/>	G46-P10-N02
			G36-P4-N01
			G46-P4-N02
			1348110A

Option combination numbers

B	BG	* Panel nut is also included with B.
G	GP	
P		

Note 1) Compared with ARX20, ARX21 is the product which adjusting spring has only been changed.

It is not the product, which does not allow the pressure more than 0.3 MPa.

Note 2) Pressure gauges are shipped together, (but not assembled).

## Specifications



Symbol



Model		ARX20
<b>Regulator construction</b>		Piston type regulator
<b>Relief mechanism</b>		Relieving type
<b>Port size</b>		Rc 1/8, 1/4
<b>Pressure gauge port size</b>		Rc 1/8, 1/4
<b>Proof pressure</b>		3.0 MPa
<b>Maximum operating pressure</b>		2.0 MPa
<b>Regulating pressure range</b>	<b>Standard type</b>	0.05 to 0.85 MPa
	<b>Low pressure type</b>	0.05 to 0.3 MPa
<b>Fluid</b>		Air
<b>Ambient and fluid temperature</b>		-5 to 60°C (No freezing)
<b>Weight</b>		110 g

**Flow Characteristics (Representative Value)**

**ARX20-01**

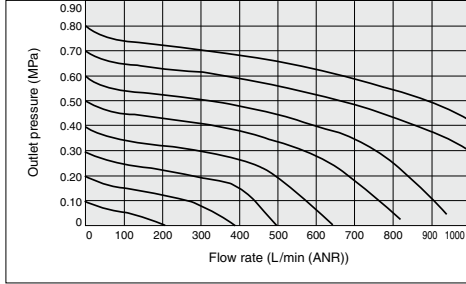

**ARX20-02**

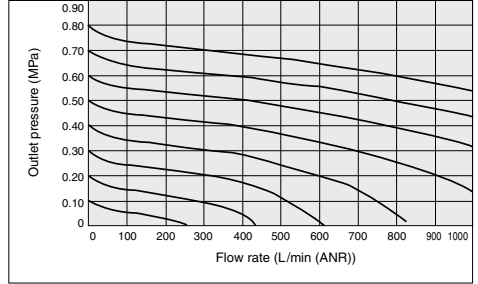

Inlet pressure: 2.0 MPa

**ARX21-01**

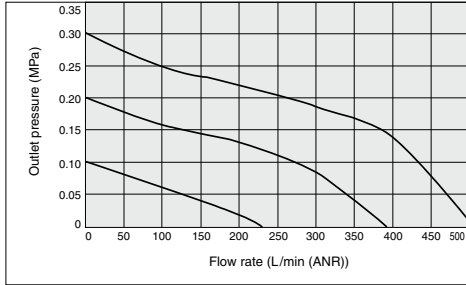

**ARX21-02**

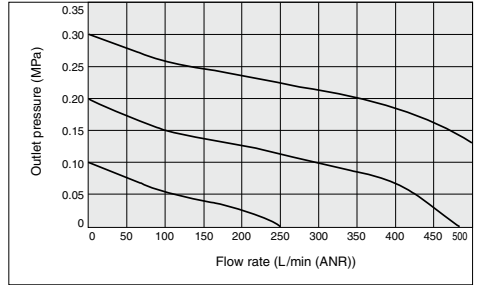

**Flow Characteristics (Representative Value)**

**ARX20**

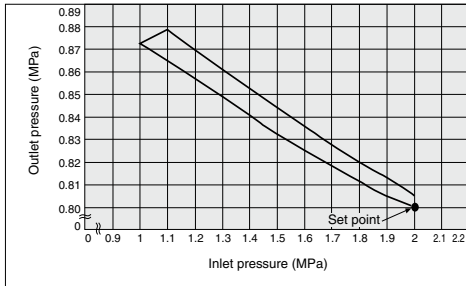

Inlet pressure: 2.0 MPa  
Outlet pressure: 0.8 MPa  
Flow rate: 60 L/min (ANR)

**ARX21**

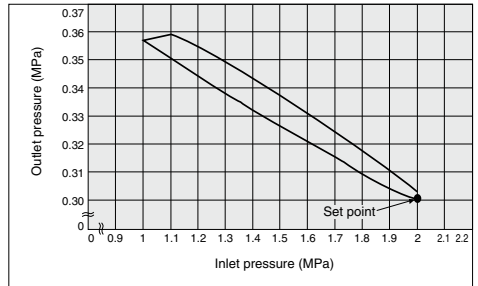

Inlet pressure: 2.0 MPa  
Outlet pressure: 0.3 MPa  
Flow rate: 60 L/min (ANR)

ARJ

AR425  
to 935

ARX

AMR

ARM

ARP

IR

IRV

VEV

SRH

SRP

SRF

VCHR

ITV

IC

ITVX

PVQ

VEF  
VEP

VER

VEA

VY1

VBA  
VBAT

AP100

# Series ARX20

## Construction

### Symbol

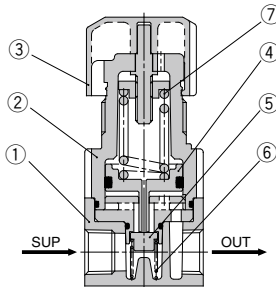
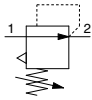

### Component Parts

No.	Description	Material	Note
1	Body	ADC	Chromate treated
2	Bonnet	POM	

### Replacement Parts

No.	Description	Material	Part no.
3	Handle	POM	1348102#1
4	Piston assembly	POM, NBR	1348104A
5	Valve	Brass, NBR	1348114#1
6	Valve spring	Stainless steel	1348109
7	Adjusting spring	Steel wire	1348108 (For 0.85 MPa)
			1348108-1 (For 0.3 MPa)

## Dimensions

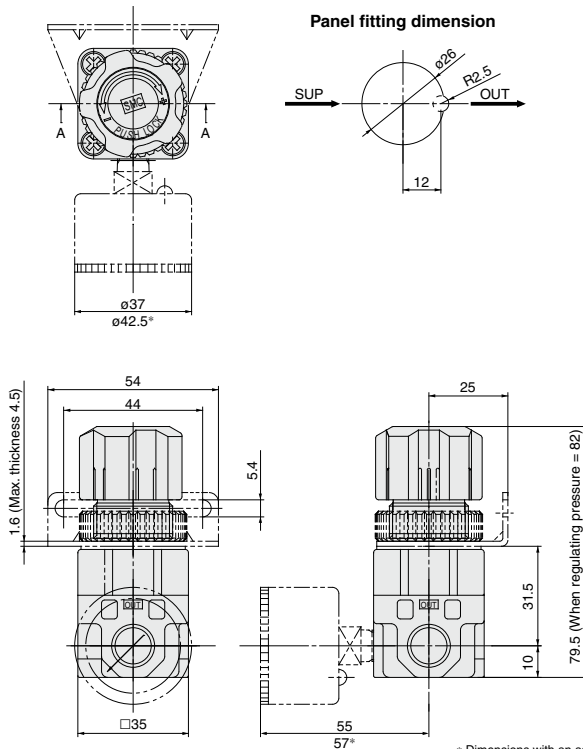

\* Dimensions with an asterisk (\*) are for the pressure gauge G46.

**Option**

**Panel Nut**

Part no.	1348110A
Material	POM, NBR (Gasket)

**Dimensions**

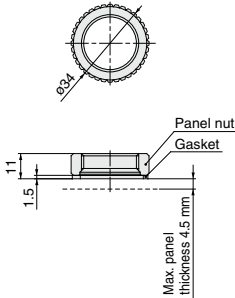

**Bracket**

Part no.	1348112
Material	SPCC (Electrophoretic coating)

**Dimensions**

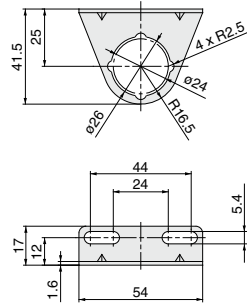

\* Install the gasket underneath the panel and bracket (bonnet side).  
Tighten the panel nut by hand without the use of tools.

**⚠ Precautions**

Be sure to read before handling.  
Refer to front matter 43 for Safety Instructions and pages 365 to 369 for Precautions on every series.

**Design and Selection**

**⚠ Warning**

- 1. Confirm the set pressure range.**  
Be sure to install safety devices in locations where output pressure above the set pressure range could lead to damage or malfunction of equipment in the outlet side.
- 2. Residual pressure relief without inlet pressure.**  
When the inlet pressure is relieved with the outlet pressure in a low pressure setting state, it may not be possible to eliminate the outlet pressure (residual pressure relief). Provide a residual pressure relief circuit when reliable elimination of the outlet pressure must be performed.

**Mounting**

**⚠ Caution**

- 1. To set the correct pressure**  
1) Set the pressure by increasing from a lower pressure to the desired setting, and lock the handle after the pressure is set.  
2) Make connections after confirming the "SUP" mark which indicates the air inlet. Reversed connections will cause malfunction.

**ARJ**  
AR425 to 935  
**ARX**  
AMR  
ARM  
ARP  
IR  
IRV  
VEX  
SRH  
SRP  
SRF  
VCHR  
ITV  
IC  
ITVX  
PVQ  
VEF  
VEP  
VER  
VEA  
VY1  
VBA  
VBAT  
AP100