

3 Port Solenoid Valve Pilot Operated Poppet Type Series VG342 Rubber Seal



[Option]
Note) CE-compliant. For DIN terminal only

Low power consumption

4.8 W DC (Standard type)
2 W DC (Energy-saving type)

No lubrication required

Possible to use in vacuum or under low pressures

External pilot
Vacuum: Up to -101.2 kPa
Low pressure: 0 to 0.2 MPa

Changeable actuation: N.C., N.O., or external pilot

Can be used as a selector or divider valve (External pilot)



Symbol

N.C.

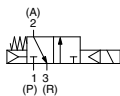

N.O.

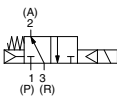

External pilot

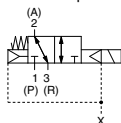

How to Order

VG342 - 1 G - 04 A - -

Valve type

Nil	Internal pilot
R	External pilot

Rated voltage *

1	100 VAC, 50/60 Hz
2	200 VAC, 50/60 Hz
3	110 VAC, 50/60 Hz
4	220 VAC, 50/60 Hz
5	24 VDC
6	12 VDC
7	240 VAC, 50/60 Hz

Note1) CE-compliant: For DIN terminal only

Note2) For other rated voltages, please consult with SMC.

Electrical entry

	CE-compliant
G	Grommet
D	DIN terminal
E	Grommet terminal
T	Conduit terminal

Light/Surge voltage suppressor

Nil	None
S	With surge voltage suppressor (Only grommet type is only available.)
Z	With light/surge voltage suppressor (Except grommet type)

CE-compliant

Nil	—
Q	CE-compliant (Note)

Note) Applicable only for DIN terminal type

Pilot valve option

Nil	Standard type
Y *	Energy-saving type (DC only)
E *	Continuous duty type

* Semi-standard

Passage symbol

Nil	External pilot
A	N.C. (Normally closed)
B	N.O. (Normally open)

Thread type

Nil	Rc
F	G
N	NPT
T	NPTF

Port size

04	1/2
06	3/4
10	1

How to Order Pilot Valve Assembly

VO307 - 1 G - X84 -

Valve option

Nil	Standard type
Y *	Energy-saving type
E *	Continuous duty type

* Semi-standard

Rated voltage *

1	100 VAC, 50/60 Hz
2	200 VAC, 50/60 Hz
3	110 VAC, 50/60 Hz
4	220 VAC, 50/60 Hz
5	24 VDC
6	12 VDC
7	240 VAC, 50/60 Hz

Note1) CE-compliant: For DIN terminal only

Note2) For other rated voltages, please consult with SMC.

CE-compliant

Nil	—
Q	CE-compliant (Note)

Note) Applicable only for DIN terminal type

Pilot valve assembly for VG342

Light/Surge voltage suppressor

Nil	None
S	With surge voltage suppressor (Only grommet type is available.)
Z	With light/surge voltage suppressor (Except grommet type)

Electrical entry

	CE-compliant
G	Grommet
D	DIN terminal
E	Grommet terminal
T	Conduit terminal

SYJ

VQZ

VP

VG

VP3

Series VG342

⚠ Caution

Light/Surge Voltage Suppressor

AC, 100 VDC or more

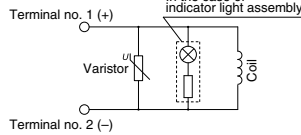

48 VDC

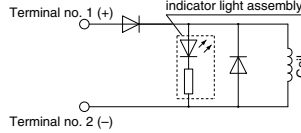

Electrical Connection

In the case of DIN terminal and terminal (with light/surge voltage suppressor), the connection is as follows. Connect each to the power supply side.

With DIN terminal block

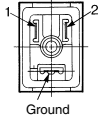

With terminal block

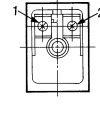

Terminal no.	1	2
DIN terminal	+	-
Terminal	+	-

How to Change Passage State

M4×0.7

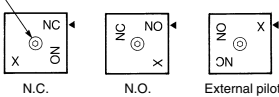

When changing the passage state, confirm that pressure has been removed from the valve.

Unscrew the M4 x 0.7 hexagon socket head cap screw in the changeover plate with the ◀ mark on the adapter plate with the character on the changeover plate. Piping is as follows.

Mounting Screw Tightening Torques

M4: 1.4 N·m

Piping

Passage	P	A	R
N.C.	Inlet	Outlet	Exhaust side (Plug, in case of 2 port valve)
N.O.	Exhaust side (Plug, in case of 2 port valve)	Outlet	Inlet
External	Universal porting (Piping of inlet pressure side is possible anywhere)		

Note 1) In the case of internal pilot, confirm that a plug is inserted to X port. If not, insert a R 1/8 plug.

Note 2) In the case of external pilot, supply air pressure from X port.

Confirm the safety sufficiently and conduct carefully when changing the passage state or restarting after changes.

Specifications

Type of actuation	In common between N.C. and N.O.	
Operation	Internal pilot type	External pilot type
Operating pressure range	0.2 to 0.9 MPa	-101.2 kPa to 0.9 MPa
	External pilot pressure	0.2 MPa
Operating pressure range	—	Equivalent operating pressure
Response time (1)	30 ms or less (at the pressure of 0.5 MPa)	
Max. operating frequency	5 c/s (Min. operating frequency: 1 c/30 days based on JIS B 8374-1981)	
Ambient and fluid temperature	-10 to 50°C (No freezing)	
Lubrication	Not required (Use turbine oil Class 1 ISO VG32, if lubricated.)	
Manual override	Push type (Non-locking)	
Mounting orientation	Unrestricted	
Impact/Vibration resistance (m/s ²) (2)	150/50	
Weight	1.1 kg *	

* For grommet type

Note 1) Based on dynamic performance test JIS B 8374-1981. (Coil temperature 20°C, at rated voltage, without surge voltage suppressor)

Note 2) Impact resistance: No malfunction occurred when it is tested with a drop tester in the axial direction and at the right angles to the main valve and armature in both energized and de-energized states every once for each condition. (Values at the initial period)

Vibration resistance: No malfunction occurred in a one-sweep test between 45 and 1000 Hz. Test was performed at both energized and de-energized states in the axial direction and at the right angles to the main valve and armature. (Values at the initial period)

Flow Characteristics

Port size	Flow characteristics											
	1 → 2 (P → A)		2 → 3 (A → R)		2 → 1 (A → P)		3 → 2 (R → A)					
	C (dm ³ /sec/bar)	b	Cv	C (dm ³ /sec/bar)	b	Cv	C (dm ³ /sec/bar)	b	Cv	C (dm ³ /sec/bar)	b	Cv
1/2	26	0.38	7.0	27	0.37	7.4	27	0.36	7.3	25	0.37	6.8
3/4	38	0.30	9.8	38	0.32	9.8	40	0.22	9.8	40	0.20	9.6

Port size	Effective area (mm ²)	
	1 → 2 (P → A)	2 → 3 (A → R)
1	210	235

Pilot Valve Assembly Specifications

Electrical entry	Grommet (G), Grommet terminal (E), Conduit terminal (T), DIN terminal (D)	
Lead wire color	100 VAC: Blue, 200 VAC: Red, 24 VDC: Red/Black	
Enclosure	Dusttight	
Coil rated voltage (V)	AC (50/60 Hz)	100, 200, 110*, 220*, 240*
	DC	24, 12*
Allowable voltage fluctuation	-15 to +10% of rated voltage	
Apparent power VA (Hz) (Note)	AC	Inrush: 12.7 (50), 10.7 (60)
	DC	7.6 (50), 5.4 (60)
Power consumption (Note)	AC	4.8 W, 5 W (With indicator light)
	DC	4.8 W, 5 W (With indicator light)

* Semi-standard

Note) At rated voltage

Valve Options

Energy-saving type: VG342□-□□□-□□□-Y (-Q)

Use "Energy-saving type" if low power consumption is required for electronic control.

Specifications different from standard are as follows.

Power consumption	2 W DC, 2.2 W (With indicator light)
-------------------	--------------------------------------

Continuous duty type: VG342□-□□□-□□□-E (-Q)

Use "Continuous duty type" if energizing the valve for a long time.

Specifications different from standard are as follows.

Apparent power VA (Hz) (Note)	AC	Inrush: 7.9 (50), 6.2 (60)
	DC	5.8 (50), 3.5 (60)
Power consumption (Note)	AC	2 W, 2.2 W (With indicator light)
	DC	2 W, 2.2 W (With indicator light)

Note) At rated voltage

DIN Connector part number

Standard	B1B09-2A
CE-compliant	GM209NJ-B17

Construction

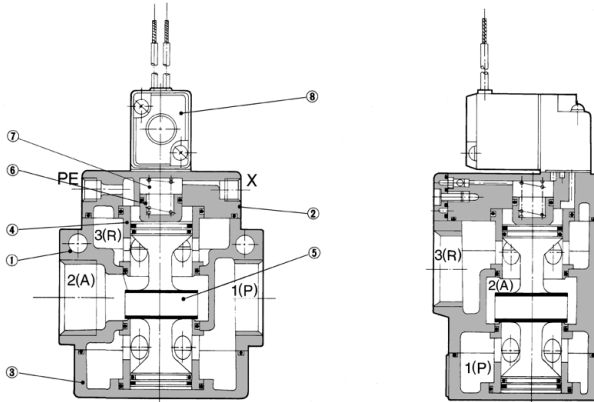

Component Parts

No.	Description	Material	Note
①	Body	Aluminum alloy	Color: Platinum silver
②	Adapter plate		
③	End plate		
④	Retainer	Brass	
⑤	Poppet valve	Aluminum alloy/NBR	
⑥	Piston	Resin	
⑦	Spring	Stainless steel	

Component Parts

No.	Description	Material	Part no.
⑧	Pilot valve assembly	—	VO307□-□□□-X84(-Q)*

* For "How to Order Pilot Valve Assembly", refer to page 1863.

⚠ Caution

Mounting Screw Tightening Torques M4: 1.4 N·m

⚠ Precautions

Be sure to read before handling.
Refer to front matter 53 for Safety Instructions and pages 3 to 8 for 3/4/5 Port Solenoid Valve Precautions.

⚠ Caution

Precautions

- Since PE port is the exhaust port of the pilot valve, do not attach a plug or reduce the port diameter.
- X port is the pressure supply port of the pilot valve and PE port is the exhaust port of the pilot valve. Avoid mismatching when piping.
- The manual portion contains a breather hole for the core. Take proper measures to prevent dust or foreign matter from accumulating in this area.

Continuous Duty

If energizing the valve for a long time, use "VG342□-□□□-□□□-E" (Pilot valve assembly: "VO307E-□□□-X84").

- This model is for continuous duty, not for high cycle rates. But even in low cycle rates, if energizing the valve more than once a day, please consult with SMC.
- Make sure to cycle valve at least once every 30 days.

How to Calculate the Flow Rate

For obtaining the flow rate, refer to front matters 42 to 45.

How to Use DIN Terminal

1. Disassembly

- After loosening the screw ①, then if the housing ② is pulled in the direction of the screw, the connector will be removed from the body of equipment (solenoid, etc.).
- Pull the screw ① out of the housing ②.
- On the bottom part of the terminal block ③, there's a cut-off part ⑨. If a small flat head screwdriver is inserted between the opening in the bottom, terminal block ③ will be removed from the cover ②. (Refer to Figure 1.)
- Remove the cable gland ④ and plain washer ⑤ and rubber seal ⑥.

2. Wiring

- Pass them through the cable ⑦ in the order of cable ground ④, washer ⑤, rubber seal ⑥, and then insert into the housing ②.
- From the terminal block ③, loosen the screw ⑩, then pass the lead wire ⑩ through, then again tighten the screw ⑩.

Note 1) Tighten within the tightening torque of 0.5 N·m ±15%.

Note 2) Cable ⑦ outside diameter: ø6 to ø8 mm

3. Assembly

- Passing through the cable ⑦, the cable gland ④, plain washer ⑤, and

rubber seal ⑥, housing ② in this order, and then connect with the terminal block ③. After that, set the terminal block ③ on the housing ②. (Push it down until you hear the click sound.)

- Putting rubber seal ⑥, plain washer ⑤, in this order into the cable introducing slit on the housing ②, then further tighten the cable gland ④ securely.
- Insert the gasket ⑧ or between the bottom part of terminal block ③ and a plug attached to equipment, and then screw ① in from the top of the housing ② to tighten it.

Note 1) Tighten within the tightening torque of 0.5 N·m ±20%.

Note 2) Connector orientation can be changed by 180 degrees depending on how to assemble the housing ② and the terminal block ③.

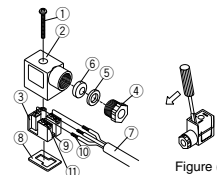

Figure 1)

SYJ

VQZ

VP

VG

VP3

Series VG342

Dimensions

Grommet (G)

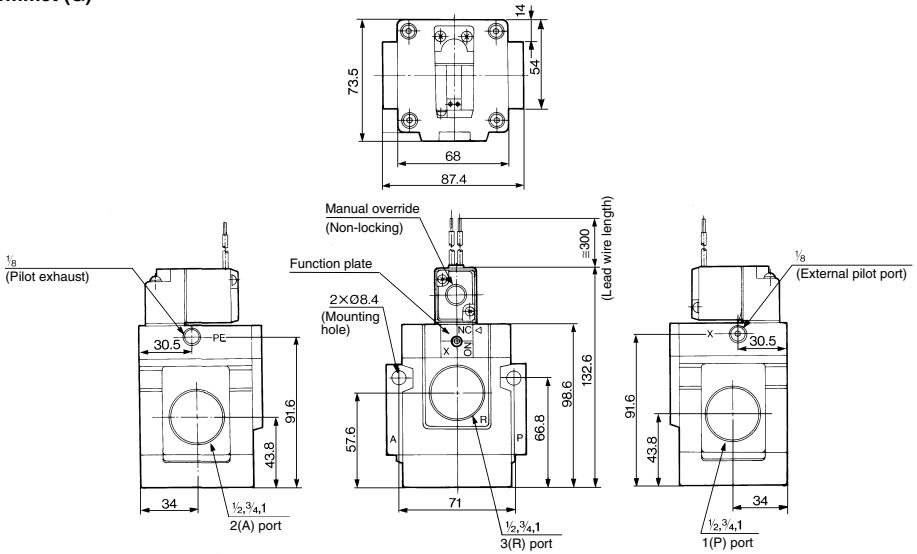

Grommet terminal (E)

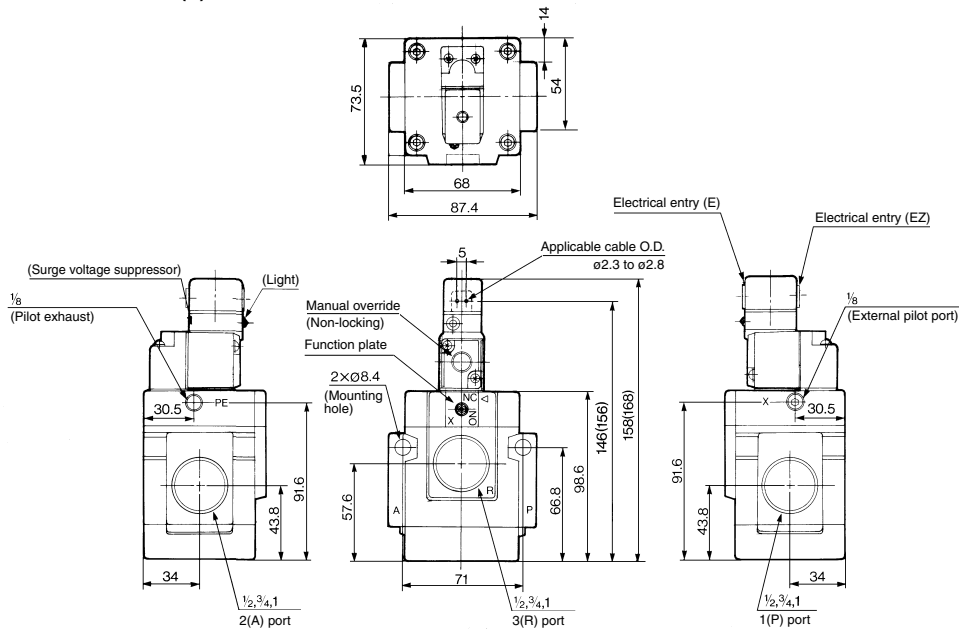

(): With light/surge voltage suppressor

3 Port Solenoid Valve Pilot Operated Poppet Type *Series VG342*

Dimensions

Conduit terminal (T)

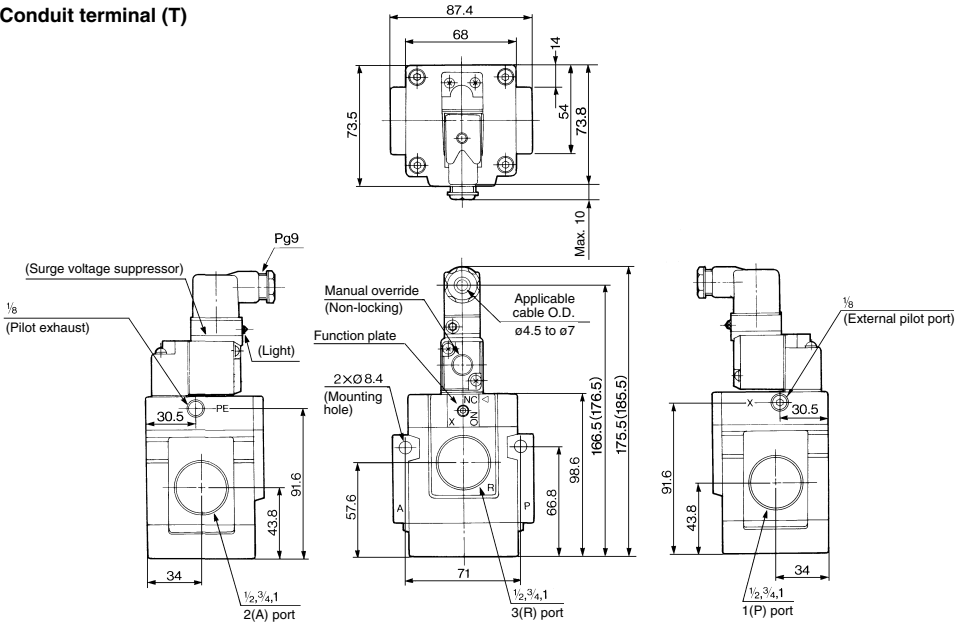

(): With light/surge voltage suppressor

DIN terminal (D)

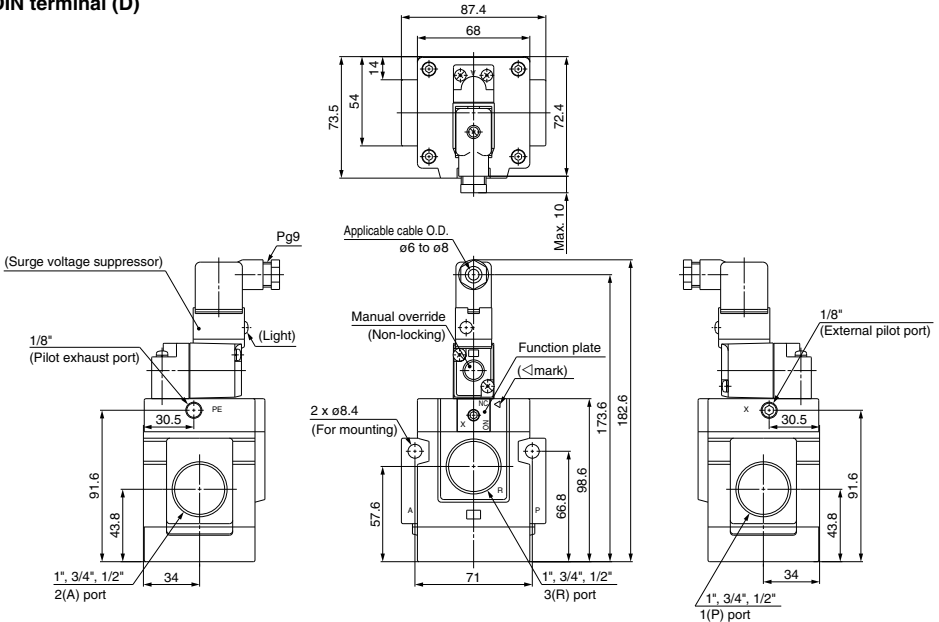

SYJ

VQZ

VP

VG

VP3