

6. Inductive compact cylinders MG-CXHC

TUV ISO-9001 : 2000 quality certified

working pressure : 140kgf/cm²

Inductive compact cylinders MG-CXHC



■■■ Index ■■■

1.MG-CXHC theoretical force.....	P6.2
2.MG-CXHC types and installations.....	P6.2
3.MG-CXHC structures and part names.....	P6.3
4.MG-CXHC spec.of seals 、 rod end connectors and rod nuts.....	P6.4
5.MG-CXHC features of proximity.....	P6.5
6.MG-CXHC order form.....	P6.7
7.MG-CXHC external dimensions.....	P6.8
●doubling acting.....	P6.8
●double rods.....	P6.10
●double rods with stroke alignment.....	P6.11
8.example for the us of check valves and flow regulators.....	P6.12

GENTLE AUTOMATIC SOLUTION SDN BHD

No.36, Jalan Industri USJ 1/13, Taman Perindustrian USJ 1, 47600 Subang Jaya, Selangor.

TEL: 603-8023 7743 / 8743 FAX: 603-8023 9743





email:sales@gentle.com.my / gpauto@tm.net.my

Theoretical force

unit : kg

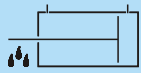
bore(mm)	rod(mm)	pressed piston area (cm ²)		theoretical force (p=70kgf/cm ²)		theoretical force (p=140kgf/cm ²)	
		push	pull	push	pull	push	pull
32	20	8.0	4.9	560	343	1120	686
40	25	12.6	7.7	880	536	1760	1072
50	30	19.6	12.6	1375	88	2750	1760
63	35	31.2	21.65	2182	1508	4343	3016
80	40	50.3	38	3519	2660	7038	5320
100	56	78.5	53.9	5498	3774	10995	7548

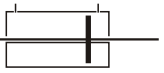
Types and installations

type	symbol	drawing	heat proof	mounting type	bore (mm)
					
doubling acting	MG-CXHC-A		MG-CXHC-AJ		32 40 50 63 80 100
double rods	MG-CXHC-C		MG-CXHC-CJ		
double rods with stroke alignment	MG-CXHC-D		MG-CXHC-DJ		

Inductive compact cylinders MG-CXHC

Structures and part names

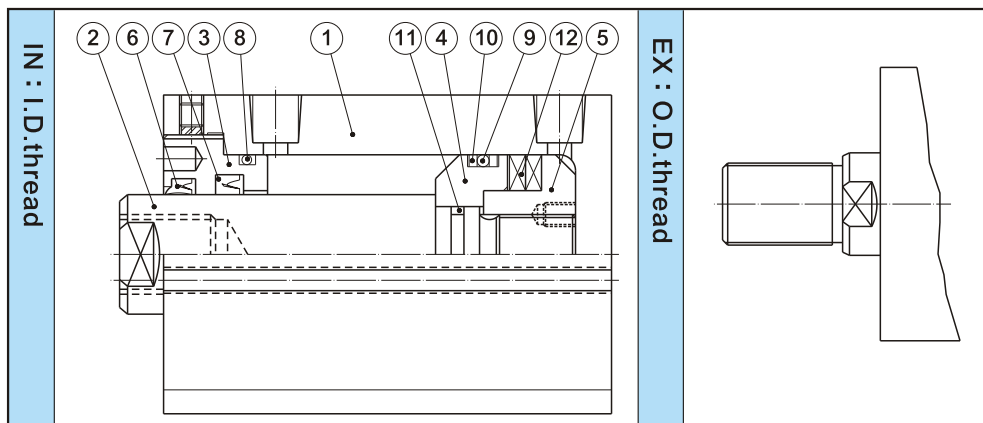

item	part name	q'ty	item	part name	q'ty
①	tube	1	⑦	rod packing	1
②	piston rod	1	⑧	rod cover o-ring	1
③	rod cover	1	⑨	piston o-ring	1
④	tube	1	⑩	back up ring	2
⑤	piston	1	⑪	cushion o-ring	1
⑥	dust seal	1	⑫	magnet	2

Seal spec.

item	⑥	⑦	⑧	⑨	⑩	⑪
name qty bore	dust seal (PU)	rod packing (PU)	rod cover o-ring (IA)	piston o-ring (IB)	piston back-up ring (PTFE)	cushion o-ring (IA)
	1	1	1	1	2	1
32	DH20	UHS20	G25	P26	P26	P12
40	DH25	UHS25	G35	P34	P34	P16
50	DH30	UHS30	G45	P44	P44	P20
63	DH35	UHS35	G55	P53	P53	G25
80	DH40	UHS40	G75	P70	P70	G30
100	DH56	UHS56	G95	P90	P90	G40

GENTLE AUTOMATIC SOLUTION SDN BHD

No.36, Jalan Industri USJ 1/13, Taman Perindustrian USJ 1, 47600 Subang Jaya, Selangor.

TEL: 603-8023 7743 / 8743 FAX: 603-8023 9743

email:sales@gentle.com.my / gpauto@tm.net.my

Connectors

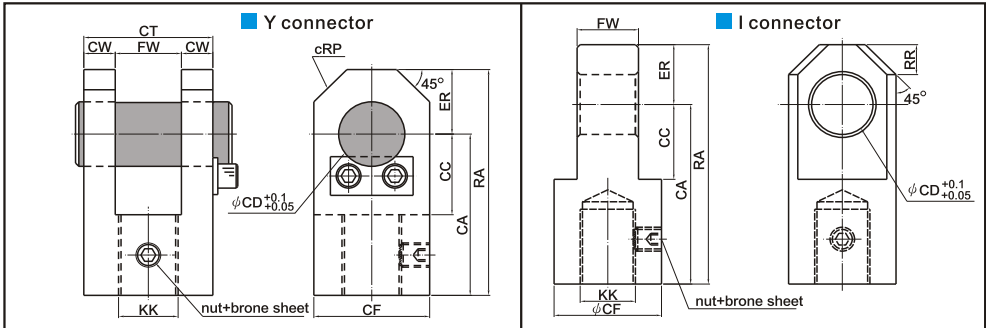

Symbol bore	KK	FW		CA		RA		CF		CD	CT	CC		ER	CW	RP	RR
		Y	I	Y	I	Y	I	Y	I			Y	I				
32	M16×1.5	20 ^{+0.40} / _{+0.10}	20 ^{-0.10} / _{-0.40}	49	69	65	85	32	38	16	45	24	24	16	12.5	8	8
40	M20×1.5	20 ^{+0.40} / _{+0.10}	20 ^{-0.10} / _{-0.40}	49	69	65	85	32	38	16	45	24	24	16	12.5	8	8
50	M24×1.5	25 ^{+0.40} / _{+0.10}	25 ^{-0.10} / _{-0.40}	60	80	80	100	40	44	20	55	35	30	20	15	10	10
63	M30×1.5	30 ^{+0.40} / _{+0.10}	30 ^{-0.10} / _{-0.40}	75	105	105	135	60	60	31.5	63	40	45	30	16.5	15	15
80	M36×1.5	30 ^{+0.40} / _{+0.10}	30 ^{-0.10} / _{-0.40}	75	105	105	135	60	60	31.5	63	40	45	30	16.5	15	15
100	M48×1.5	40 ^{+0.40} / _{+0.10}	40 ^{-0.10} / _{-0.40}	100	120	140	160	70	70	40	78	50	50	40	19	20	20

Rod nuts

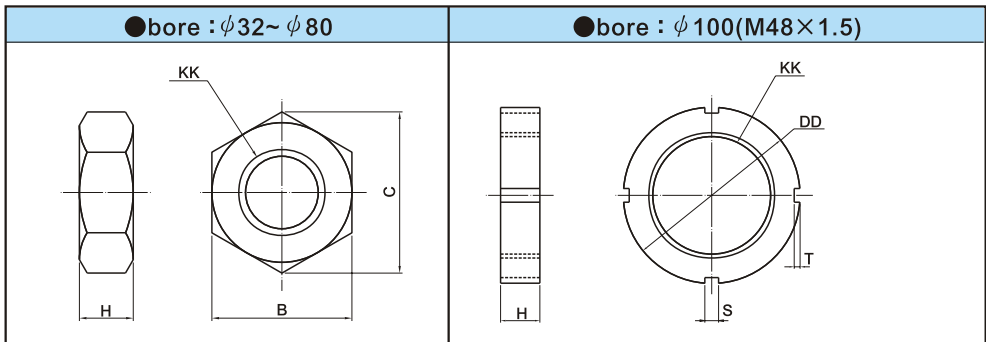

KK	B	C	H	DD	S	T
M16×1.5	24	27	10	—	—	—
M20×1.5	30	34	11	—	—	—
M24×1.5	36	41	13	—	—	—
M30×1.5	41	47	17	—	—	—
M36×1.5	50	57	18	—	—	—
M48×1.5	—	—	18	70	6	2.5

Inductive compact cylinders MG-CXHC

Features of proximity(sensors)

item	model	LED position	name	voltage (v)	current (ma)	cadacity	response time	conn-ction type	protect-ion class	LED color	wire	inner voltage	temper-ature
	JFS-04	top	stand-ard	DC4-24 AC4-120	5~40	6(3)W 8(4)VA	ON+OFF <1ms	open	IP-67	red	φ 3.3mm 2C black 2m	max. 2.5v	-10° +70°C
	- U		3 wri-se	DC4-24	OFF:7mA (24V) ON:16mA (24V)	50MA	ON+OFF <2ms				φ 3.3mm 3C black	max. 0.5v	

Order form

Positions of proximity

JFS-04 — ① — ②M × ③

JFS-04 : suitable for MG-CXHC		
①	kind	(1)U or space : standard (2)PNP : 3 wri-se
②	wire length	(1)space : 2M (2)5M
③	q'ty	unit : piece

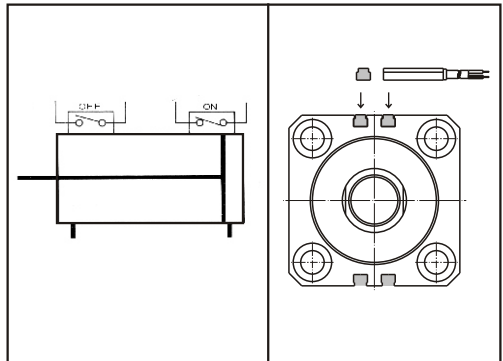

External dimensions

● JFS-04

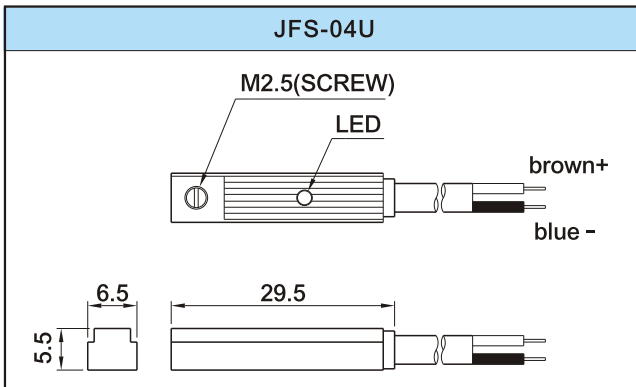

6.5

Circuits diagrams

■ register / relay

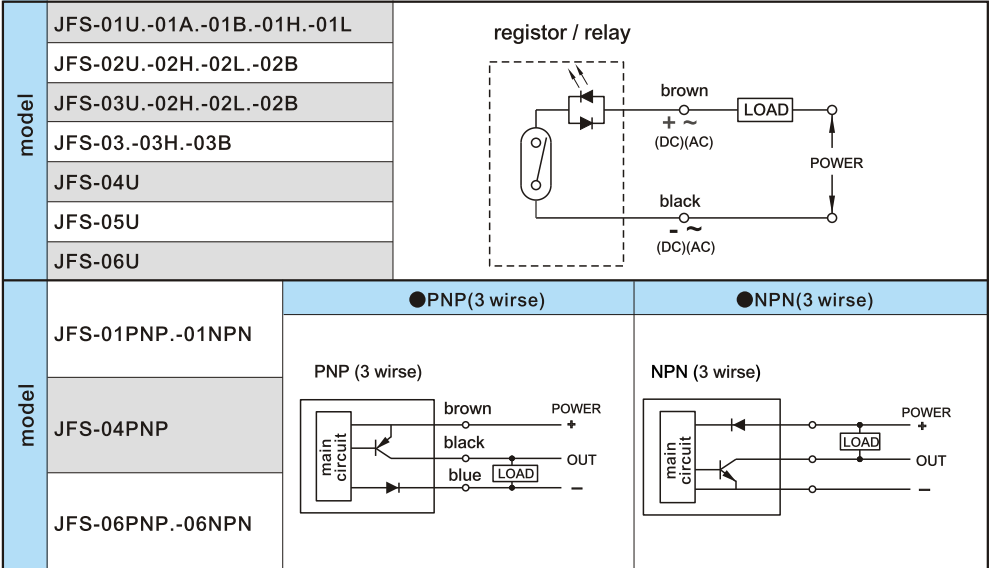

■ PLC programmable

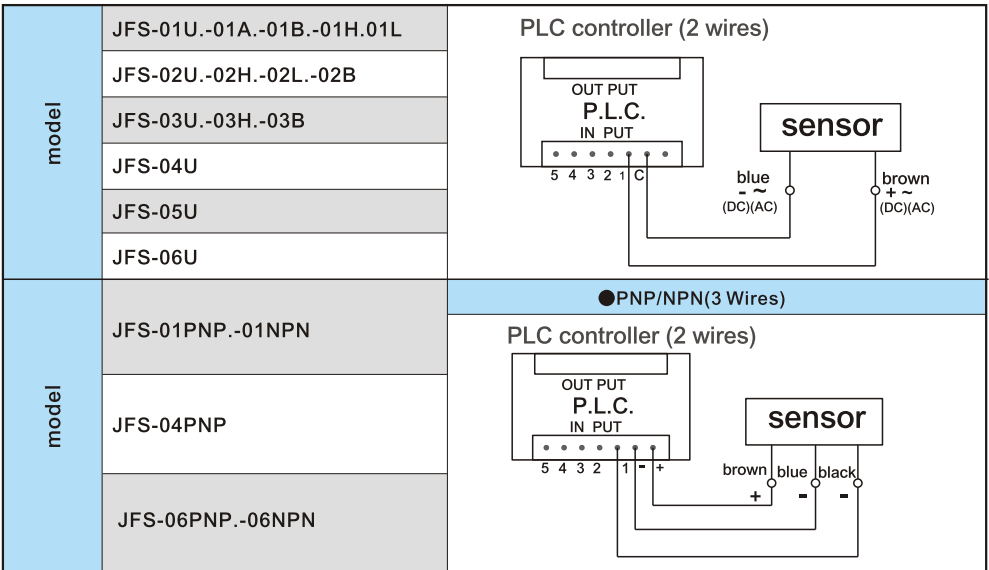

Order form

MG-CXHC A — J — IN — SD — 50 × 30 — 25mm — T×n — 1 — 02 — A

① — ② — ③ — ④ — ⑤ — ⑥ — ⑦ — ⑧ — ⑨ — ⑩ — ⑪

MG-CXHC : Inductive compact cylinders

①	type	(1) A : doubling acting (2) C : double rods (3) D : double rods with stroke alignment
②	options	J : with heat/errosion proof (note : "space"if not be used)
③	rod thread	(1) IN : I.D.thread (2) EX : O.D.thread
④	installations	(1) SD : basic (2) La : foot type
⑤	bore(mm)	(1) SD : 32 , 40 , 50 , 63 , 80 , 100 (2) LA : 40 , 50 , 63 , 80 , 100
⑥	stroke(mm)	no "standard stroke"table
⑦	stroke alignment	only forward alignment and aligned length ≤ stroke length
⑧	sensor and q'ty	(1)T : 2 wires, 2 meters P : PNP3 wires, 2 meters N : NPN3 wires, 2 meters (2)n : q'ty
⑨	packing	{1}1 : (PU)(standard usage) (2)2 : (NBR) (3)3 : (FPM)
⑩	flow regulator	(1)02 : 1/4"(12 ℓ/min) (2)03 : 3/8"(20 ℓ/min) (3)04 : 1/2"(30 ℓ/min)
⑪	check valve	(1)A : 3/8"(50 ℓ/min) (2)B : 3/4"(125 ℓ/min) (3)C : 1 1/2"(320 ℓ/min)

Inductive compact cylinders MG-CXHC

External dimensions

MG-CXHC-A-SD : double acting,basic

IN

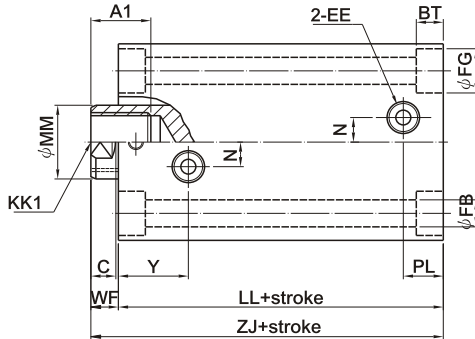
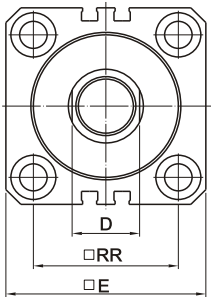

EX SD / LA

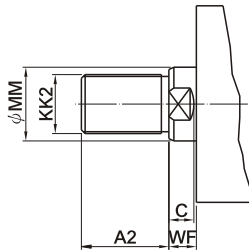

MG-CXHC-C-SD : double acting,foot flange

IN

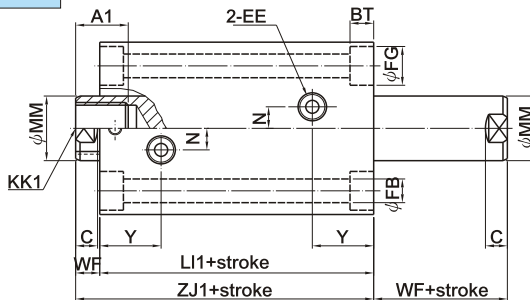
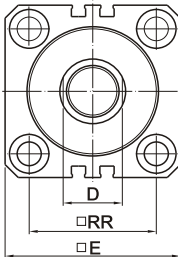

bore Symbol	ID.thread		O.D.thread		BT	C	D	E	EE	FB	FG	LL	LL1	MM	N	PL	RR	WF	Y	ZJ	ZJ1
	A1	KK1	A2	KK2																	
32	15	M12×1.75	25	M16×1.5	6.5	9	17	62	Rc1/4	7	11	73	84	20	10	17	47	10	27	83	94
40	20	M16×2.0	30	M20×1.5	8.6	9	21	70	Rc1/4	9	14	70	81	25	10	16	52	10	27	80	91
50	24	M20×2.5	35	M24×1.5	10.8	9	27	80	Rc1/4	11	17.5	75	87	30	10	16	58	11	28	86	98
63	33	M27×3.0	45	M30×1.5	13	11	32	94	Rc1/4	14	20	84	94	35	10	18	69	13	30	97	107
80	33	M30×3.5	55	M36×1.5	15.2	14	37	114	Rc3/8	16	23	95	106	40	15	22	86	17	35	112	123
100	40	M36×4.0	70	M48×1.5	17.5	14	50	134	Rc3/8	18	26	100	114	56	15	25	102	17	39	117	131

External dimensions

MG-CXHC-A-LA : double acting, basic

IN bore : $\phi 63$ 、 $\phi 80$ 、 $\phi 100$ with 2 sensor grooves

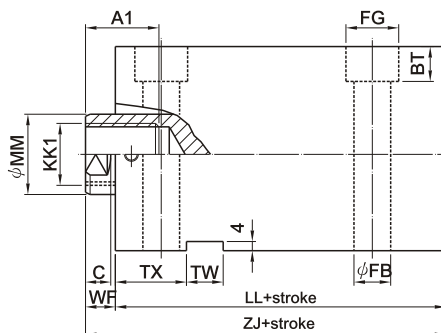
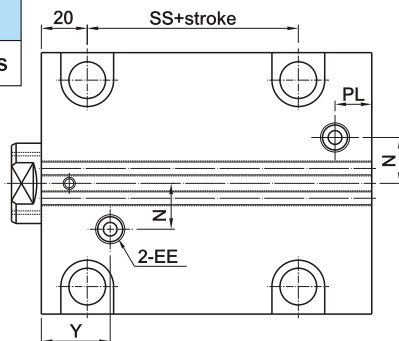
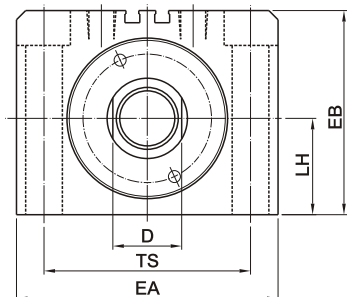

EX

Bore : $\phi 40$, $\phi 50$ with 1 sensor groove

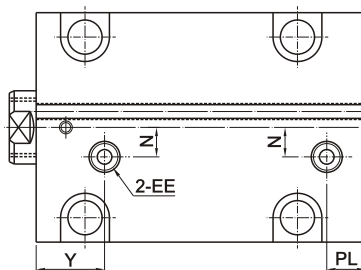
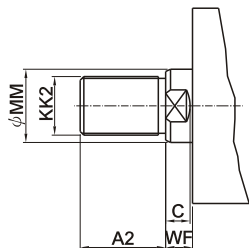

Symbol bore	ID.thread		O.D.thread		BT	C	D	EA	EB	EE	FB	FG	LH	LL	MM	N	PL	SS	TS	TW	TX	WF	Y	ZJ
	A1	KK1	A2	KK2																				
40	20	M16×2.0	30	M20×1.5	10.8	9	21	80	64	Rc1/4	11	18	29	70	25	10	16	23	62	12	28	10	27	80
50	24	M20×2.5	35	M24×1.5	13	9	27	94	74	Rc1/4	14	20	34	75	30	10	16	27	74	14	29	11	28	86
63	33	M27×3.0	45	M30×1.5	15.2	11	32	114	89	Rc1/4	16	23	42	84	35	20	18	32	90	16	31	13	30	97
80	33	M30×3.5	55	M36×1.5	15.2	14	37	134	109	Rc3/8	16	23	52	95	40	25	22	41	110	16	34	17	35	112
100	40	M36×4.0	70	M48×1.5	17	14	50	160	129	Rc3/8	18	26	62	100	56	25	25	44	134	16	34	17	39	117

External dimensions

MG-CXHC-C-LA : foot flange

IN

bore : $\phi 63$ 、 $\phi 80$ 、 $\phi 100$
with 2 sensor grooves

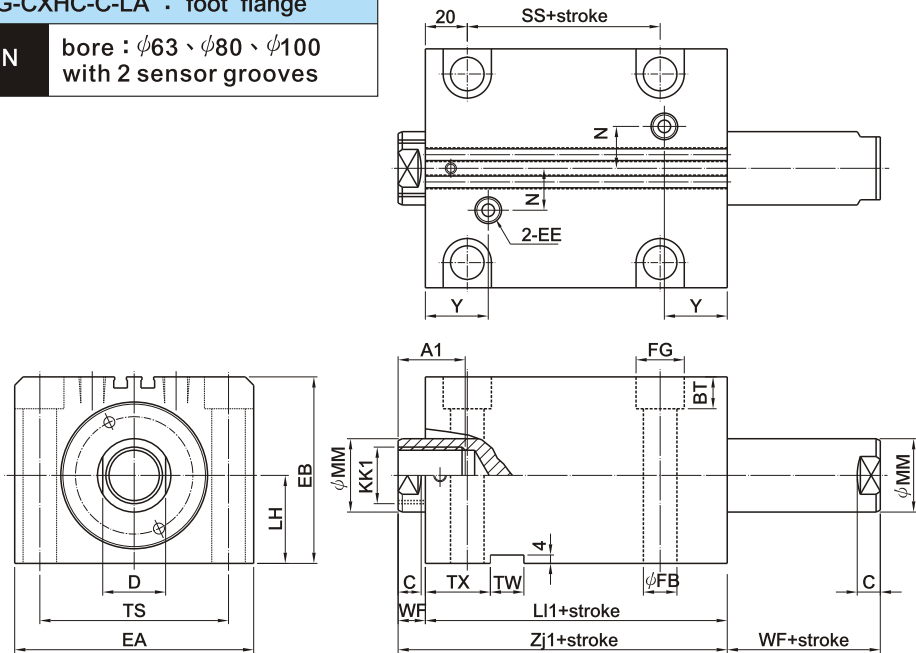

EX

bore : $\phi 40$, $\phi 50$ with 1 sensor groove

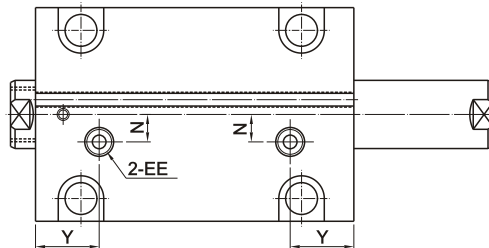
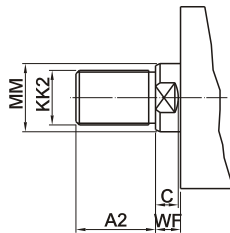

Stroke bore	ID.thread		O.D.thread		BT	C	D	EA	EB	EE	FB	FG	LH	LL1	MM	N	SS	TS	TW	TX	WF	Y	ZJ1
	A1	KK1	A2	KK2																			
40	20	M16×2.0	30	M20×1.5	10.8	9	21	80	64	Rc1/4	11	18	29	81	25	10	23	62	12	28	10	27	91
50	24	M20×2.5	35	M24×1.5	13	9	27	94	74	Rc1/4	14	20	34	87	30	10	27	74	14	29	11	28	98
63	33	M27×3.0	45	M30×1.5	15.2	11	32	114	89	Rc1/4	16	23	42	94	35	20	32	90	16	31	13	30	107
80	33	M30×3.5	55	M36×1.5	15.2	14	37	134	109	Rc3/8	16	23	52	106	40	25	41	110	16	34	17	35	123
100	40	M36×4.0	70	M48×1.5	17	14	50	160	129	Rc3/8	18	26	62	114	56	25	44	134	16	34	17	39	131

External dimensions

MG-CXHC-SD : double rods with stroke alignment, basic

IN

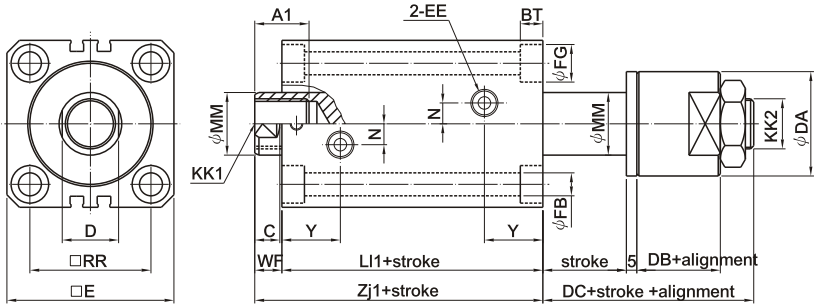

EX SD / LA

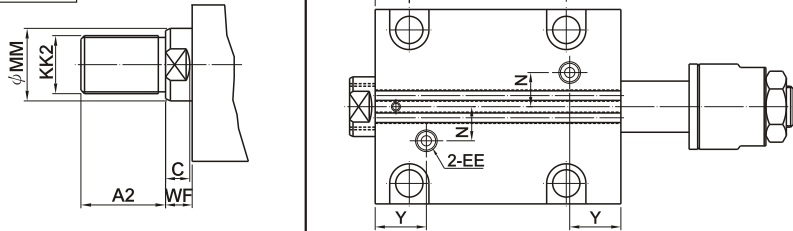

MG-CXHC-LA : double rods with stroke alignment, foot flange

IN

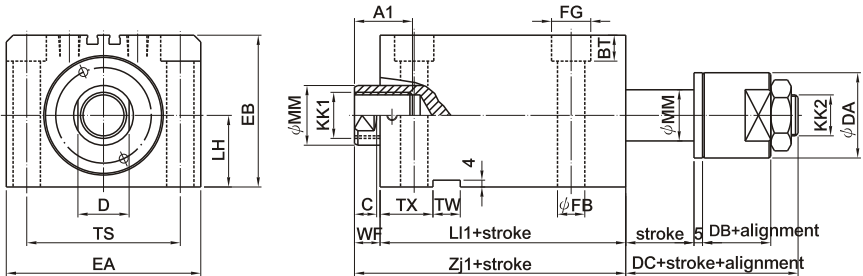

Stroke box	ID.thread		O.D.thread		C	D	DA	DB	DC	E	EA	EB	EE	LH	LL	MM	N	BT		FB		FG		SS	TS	RR	TW	TX	WF	Y	ZJ1
	A1	KK1	A2	KK2														SD	LA	SD	LA	SD	LA								
32	15	M12×1.75	25	M16×1.5	9	17	38	20	36	62	—	—	Rc1/4	—	84	20	10	6.5	—	7	—	11	—	—	—	47	—	10	27	94	
40	20	M16×2.0	30	M20×1.5	9	21	44	25	42	70	80	64	Rc1/4	29	81	25	10	8.6	10.8	9	11	14	17.5	23	62	52	12	28	10	27	91
50	24	M20×2.5	35	M24×1.5	9	27	50	25	48	80	94	74	Rc1/4	34	87	30	10	10.8	13	11	14	18	20	27	74	58	14	29	11	28	98
63	33	M27×3.0	45	M30×1.5	11	32	55	25	49	94	114	89	Rc1/4	42	94	35	10	13	15.2	14	16	20	23	32	90	69	16	31	13	30	107
80	33	M30×3.5	55	M36×1.5	14	37	60	25	52	114	134	109	Rc3/8	52	106	40	15	15.2	15.2	16	16	23	23	41	110	86	16	34	17	35	123
100	40	M36×4.0	70	M48×1.5	14	50	80	35	62	134	160	129	Rc3/8	62	114	56	15	17.5	17	18	18	26	26	44	134	102	16	34	17	39	131

Example for the use of check valves and flow regulators



●hydraulic circuit diagram

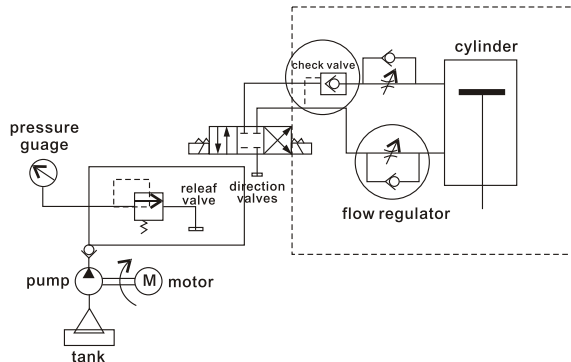

note :

- 1.Regulate the speed of cylinders motions.
- 2.The control direction of flow speed regulator needs to be carefully taken while installing a regulator onto a cylinder.
- 3.Speed regulator is very useful(1)to prevent an abnormal cylinder movement, (2)to hold off the back pressure caused by mold ejection or (3)to justify the pressure dropping due to tubing bore variation caused by temperature change.

flow regulator					check valve				
Spec.	bore (rc)	1/4	3/8	1/2	Spec.	bore (rc)	3/8	3/4	1 1/2
	flow (l/min)	12	20	30		flow (l/min)	50	125	320
Use	1.Regulate the speed of cylinder's motions 2.The correction of flow direction is necessary.				Use	1.To prevent a stroke dropping dus to a load overweight or intesnal leakage 2.Working pressure : 210kgf/cm ²			
	order form	FL02	FI03	FI04		order form	PCV03	PCV06	PCV15