

# 2-Color Indication Type Solid State Auto Switch Direct Mounting Style

## D-M9NW(V)/D-M9PW(V)/D-M9BW(V)



### Grommet

- 2-wire load current is reduced (2.5 to 40 mA).
- Flexibility is 1.5 times greater than the conventional model (SMC comparison).
- Using flexible cable as standard spec.
- The proper operating range can be determined by the color of the light. (Red → Green ← Red)

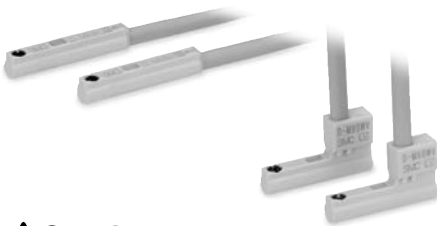

### ⚠ Caution

#### Precautions

Fix the auto switch with the existing screw installed on the auto switch body. The auto switch may be damaged if a screw other than the one supplied is used.

### Auto Switch Internal Circuit

#### D-M9NW, D-M9NWV

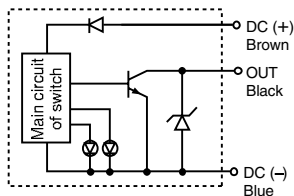

#### D-M9PW, D-M9PWV

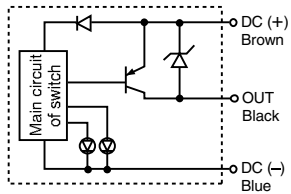

#### D-M9BW, D-M9BWV

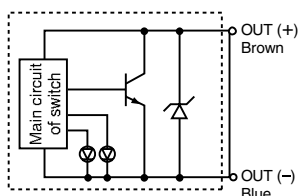

### Indicator light / Display method

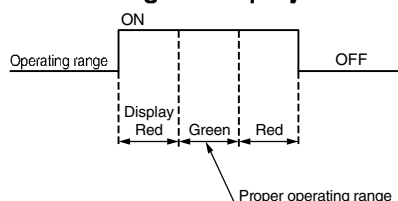

### Auto Switch Specifications

PLC: Programmable Logic Controller

D-M9□W, D-M9□WV (With indicator light)						
Auto switch model	D-M9NW	D-M9NWV	D-M9PW	D-M9PWV	D-M9BW	D-M9BWV
Electrical entry direction	In-line	Perpendicular	In-line	Perpendicular	In-line	Perpendicular
Wiring type	3-wire			2-wire		
Output type	NPN		PNP		—	
Applicable load	IC circuit, Relay, PLC				24 VDC relay, PLC	
Power supply voltage	5, 12, 24 VDC (4.5 to 28 V)				—	
Current consumption	10 mA or less				—	
Load voltage	28 VDC or less		—		24 VDC (10 to 28 VDC)	
Load current	40 mA or less				2.5 to 40 mA	
Internal voltage drop	0.8 V or less at 10 mA (2 V or less at 40 mA)				4 V or less	
Leakage current	100 μA or less at 24 VDC				0.8 mA or less	
Indicator light	Operating range ..... Red LED illuminates. Proper operating range ..... Green LED illuminates.					
Standard	CE marking					

- Lead wires — Oilproof flexible heavy-duty vinyl cord:  $\phi 2.7 \times 3.2$  ellipse, 0.15 mm<sup>2</sup>, 2 cores (D-M9BW(V)), 3 cores (D-M9NW(V), D-M9PW(V))

Note 1) Refer to page 1272 for solid state auto switch common specifications.

Note 2) Refer to page 1272 for lead wire lengths.

### Mass

(g)

Auto switch model	D-M9NW(V)	D-M9PW(V)	D-M9BW(V)	
Lead wire length (m)	0.5	8	8	7
	1	14	14	13
	3	41	41	38
	5	68	68	63

### Dimensions

(mm)

#### D-M9□W

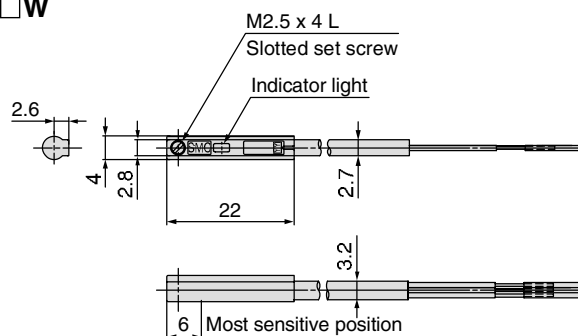

#### D-M9□WV

