

3 Port Solenoid Valve Direct Operated Poppet Type Series VT325 Rubber Seal

Compact yet provides a large flow capacity

Dimensions (W x H x D)....55 x 118 x 53
(Grommet)

C: 0.61 dm³/(s·bar)
{Rc 3/8 (Passage 2 → 3)}

A single valve with 6 valve functions

(Universal porting type)

Six valve functions can be attained by selecting the piping ports. (Enabling the N.C. valve, N.O. valve, divider valve, selector valve, etc. to be used as desired.)

Suitable for use in vacuum applications

-101.2 kPa

(For vacuum specifications type: VT/VO325V)



JIS Symbol

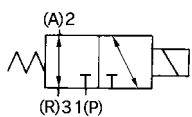

How to Order

VT325 □ - **02** **1** **G** □ - □ - □ - □

For manifold:
Enter "VO".
Valve option

Nil	Standard
V*	For vacuum

* Option

Port size

02	1/4
03	3/8
00	Without connection port (For manifold)

Rated voltage

1	100 VAC, 50/60 Hz
2	200 VAC, 50/60 Hz
3*	110 VAC, 50/60 Hz
4*	220 VAC, 50/60 Hz
5	24 VDC
6*	12 VDC
7*	240 VAC, 50/60 Hz
9*	Other

* Option

Manual override

Nil	Non-locking type
M	Locking type (Tool required)

Thread type

Nil	Rc
F	G
N	NPT
T	NPTF

CE-compliant

Nil	—
Q*	CE-compliant

* Electrical entry:
D/DO/DL/DLO only

Surge voltage suppressor

Nil	None
S	With surge voltage suppressor (AC: Can be attached to Grommet, Conduit, Conduit terminal. DC: Can be attached to Grommet, Conduit, Conduit terminal.)

Electrical entry

G	Grommet, Lead wire length 300 mm
C	Conduit
D	DIN terminal
T	Conduit terminal
TL**	Terminal with indicator light
DL**	DIN terminal with indicator light

** For the coil rated voltage (option *), please contact SMC.

Manifold

Model	Applicable manifold	Accessory
VO325-00□□(-Q)	B mount common exhaust type	Gasket (DXT083-13-1) Bolts (DXT083-19-1, 2 pcs.)

Specifications

Type of actuation	Direct operated type 2 position single solenoid
Fluid	Air
Operating pressure range	0 to 1.0 MPa
Ambient and fluid temperature	5 to 50°C
Max. operating frequency	5 Hz
Response time (1)	30 ms or less (at the pressure of 0.5 MPa)
Lubrication	Not required (Use turbine oil Class 1 ISO VG32, if lubricated.)
Manual override	Non-locking push type
Shock/Vibration resistance (2)	150/50 m/s ²
Enclosure	Dustproof



Note 1) Based on dynamic performance test, JIS B 8374-1981. (Coil temperature: 20°C, at rated voltage, without surge suppressor)

Note 2) Impact resistance: No malfunction occurred when it is tested with a drop tester in the axial direction and at the right angles to the main valve and armature in both energized and de-energized states every once for each condition. (Values at the initial period)

Vibration resistance: No malfunction occurred in a one-sweep test between 45 and 1000 Hz. Test was performed at both energized and de-energized states in the axial direction and at the right angles to the main valve and armature. (Values at the initial period)

Solenoid Specifications

Electrical entry	Grommet, Conduit, DIN terminal, Conduit terminal		
Coil rated voltage	100, 200 VAC, 50/60 Hz, 24 VDC		
Allowable voltage fluctuation	-15 to +10% of rated voltage		
Apparent power (3)	AC	Inrush	50 Hz: 75 VA 60 Hz: 60 VA
		Holding	50 Hz: 27 VA 60 Hz: 17 VA
	DC		12 W
	Power consumption (3)	DC	



Note 3) At rated voltage

Series VT325

Flow Characteristics/Mass

Valve model	Port size	Flow characteristics												Mass
		1 → 2 (P → A)			2 → 3 (A → R)			3 → 2 (R → A)			2 → 1 (A → P)			
		C [dm ³ /(s·bar)]	b	Cv	C [dm ³ /(s·bar)]	b	Cv	C [dm ³ /(s·bar)]	b	Cv	C [dm ³ /(s·bar)]	b	Cv	
VT325	1/4	5.5	0.37	1.4	5.9	0.35	1.5	5.5	0.33	1.4	5.7	0.32	1.4	0.55 kg (For AC) 0.60 kg (For DC)
VT325V (Vacuum spec. type)		5.5	0.37	1.4	6.1	0.37	1.6	5.7	0.34	1.4	6.6	0.25	1.5	
VT325	3/8	5.5	0.37	1.4	6.1	0.37	1.6	5.7	0.34	1.4	6.6	0.25	1.5	0.55 kg (For AC) 0.60 kg (For DC)
VT325V (Vacuum spec. type)		5.5	0.37	1.4	6.1	0.37	1.6	5.7	0.34	1.4	6.6	0.25	1.5	

Note) Values for a single valve unit. It differs in the manifold case. Refer to manifold specifications on page 1620.

Option

1. For vacuum

Pressure range -101.2 kPa to 0.1 MPa

This vacuum model has less air leakage than the standard model under low pressure. It is recommended for vacuum application.

⚠ Caution

1) Since this valve has slight air leakage, it can not be used for holding vacuum (including positive pressure holding) in the pressure container.

2. With surge voltage suppressor, with indicator light

Surge Voltage Suppressor

	AC	DC
Grommet (GS)		
Conduit (CS)		
Conduit terminal (TS)		

Circuit for Indicator Light

	AC	DC
DIN terminal with indicator light (DL)		
Conduit terminal with indicator light (TL)		

• Grommet type

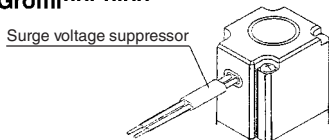

3. Manual override with lock

- Using a screwdriver, push the manual override button that is located in the head portion of the solenoid valve in order to directly push the spool valve downward, thus causing the valve to switch.
- With the button remaining pushed down, turn it approximately 90° clockwise or counterclockwise to maintain the manual override locked state.
- To revert to the original state, keep the button pushed down and turn it approximately 90° clockwise.

Construction

De-energized

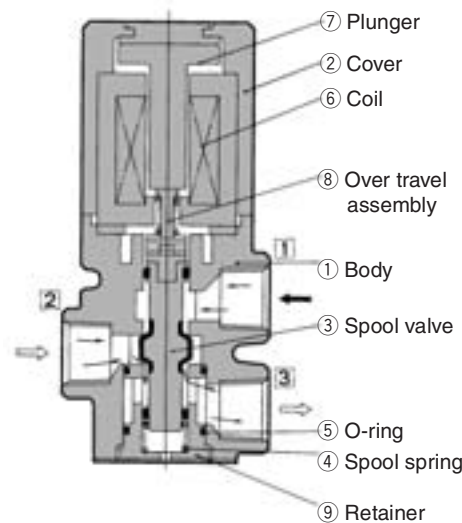

Energized

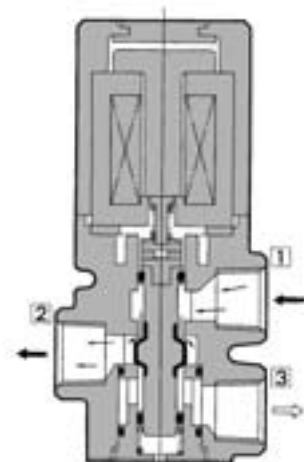

Operation principle

<De-energized>

The spool (3) is pushed upward by the force of the spring (4) and the air passage between port (2) and port (3) is opened and port (1) is blocked.

Air flow direction: 1 ↔ Block, 2 ↔ 3

<Energized>

When the coil (6) is energized the plunger (7) is pulled down depressing the spool (3) via the overtravel assembly (8) and the air passage between port (1) and port (2) is opened and port (3) is blocked.

Air flow direction: 1 ↔ 2, 3 ↔ Block

Component Parts

No.	Description	Material	Note
1	Body	Aluminum die-casted	Platinum silver
2	Cover	Aluminum die-casted	Platinum silver
3	Spool valve	Aluminum, NBR	

Dimensions

Grommet (G)

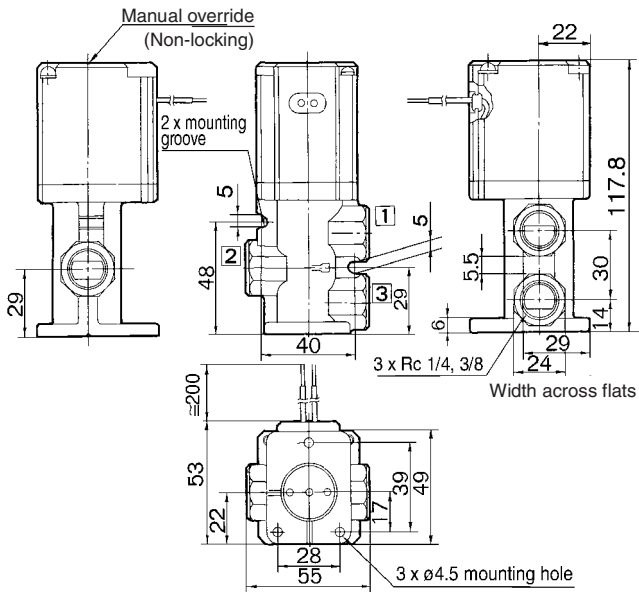

Conduit (C)

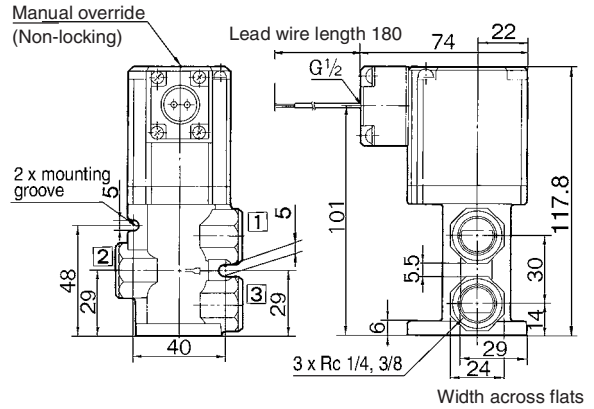

DIN terminal (D)

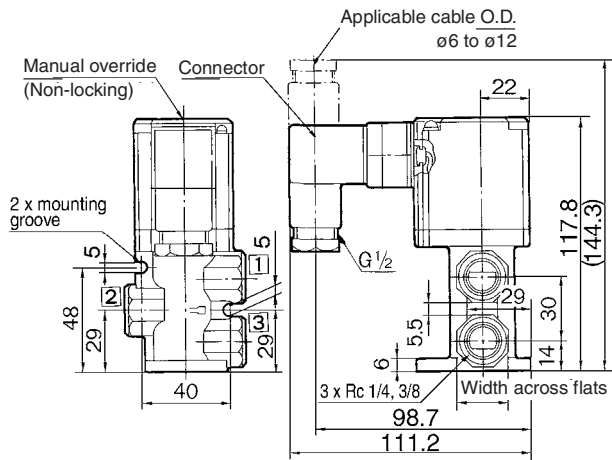

Conduit terminal (T)

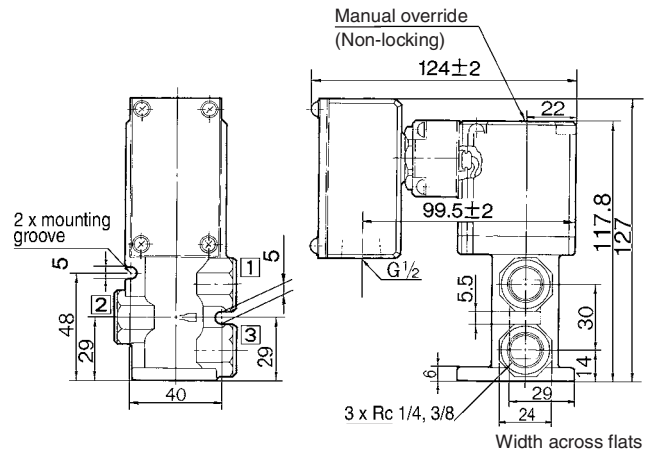

With locking manual override

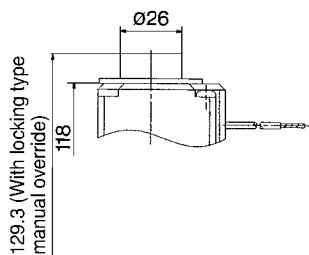

Conduit terminal with indicator light (TL)

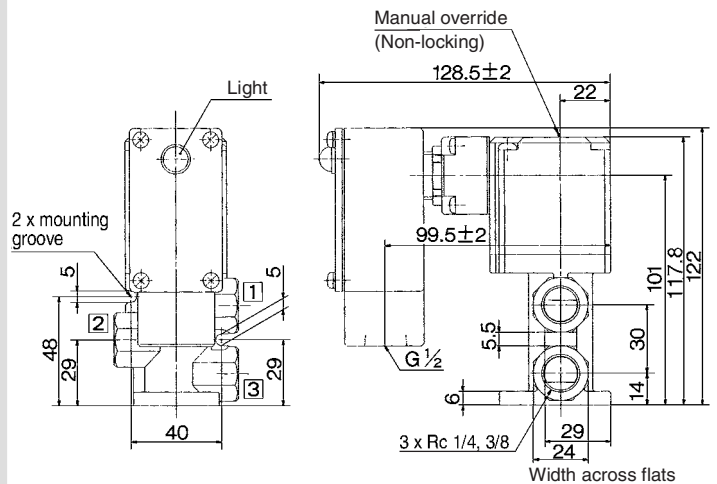

Series VT325

Manifold Specifications

Series VT325 Manifold Model has a B mount style with common exhaust.

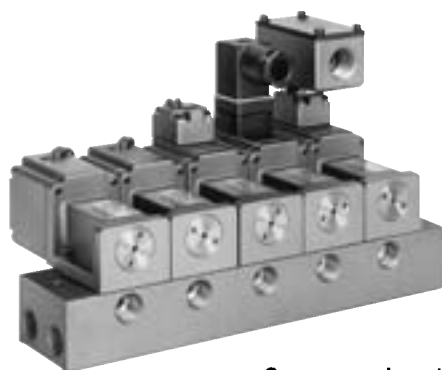

Common exhaust

How to Order Manifold

VVT34 **0** - **05** **1** - **□** **□**

Porting specifications

Symbol	P	A	R
0	Side	Side	Side
1	Side	Bottom	Side

Valve stations

02	2 stations
⋮	⋮
17	17 stations

Port size

Symbol	Port size
02	1/4
03	3/8

Exhaust port type

1	Common exhaust
---	----------------

Thread type

Nil	Rc
F	G
N	NPT
T	NPTF

* Instruct by specifying the valves and blanking plate to be mounted on the manifold along with the manifold base model no.
 <Example>
 VVT340-051..... 1 pc.
 VO325-001G..... 4 pcs.
 DXT083-21A..... 1 pc.

Manifold Specifications

Manifold type	B mount					
Max. number of stations	17 stations ^{Note)}					
Applicable solenoid valve	VO325-00□□(-Q)					
Exhaust port type	Port location/Port size			Port direction		
	P	A	R	P	A	R
Common	Base	Base	Base	Side	Side/Bottom	Side
	1/4, 3/8	1/4, 3/8	1/4, 3/8			
Option	Blanking plate (With gasket, screw)				DXT083-21A	



Note) If there are more than 4 stations, supply air from both P ports and exhaust from both R ports.

Accessory for Applicable

Description	Part no.	Qty.
Manifold gasket	DXT083-13-1	1 pc.
Hexagon socket head screw	DXT083-19-1	2 pcs.

Flow Characteristics/Mass

Valve model	Flow characteristics												Mass
	1 → 2 (P → A)			2 → 3 (A → R)			3 → 2 (R → A)			2 → 1 (A → P)			
	C [dm ³ /(s·bar)]	b	Cv	C [dm ³ /(s·bar)]	b	Cv	C [dm ³ /(s·bar)]	b	Cv	C [dm ³ /(s·bar)]	b	Cv	
VO325	4.1	0.24	1.0	4.4	0.18	1.0	4.5	0.15	1.0	4.3	0.23	1.0	0.58 kg
VO325V (Vacuum spec. type)													0.63 kg
													0.63 kg (For DC)

⚠ Precautions

⚠ Warning

When mounting valves on the manifold base, the mounting orientation is decided. If it is mounted in the wrong direction, connected equipment may malfunction. Mount it by referring to external dimensions on page 1621. Besides, the external dimensions are showing the case of N.C. specifications.

⚠ Caution

Changing from N.C. to N.O.

The valves are assembled as N.C. valves at the time of shipment.

By removing the two retaining screws from the desired valves, and rotating each valve body 180° and reassembling it on the manifold base, it is possible to reassemble an N.C. valve as an N.O. valve. (When doing so, make sure that a gasket is attached to the mounting surface of the valve.) Properly tighten the screws.

The tightening torque of the retaining screws is 3 N·m.

3 Port Solenoid Valve Direct Operated Poppet Type **Series VT325**

Dimensions

Common exhaust

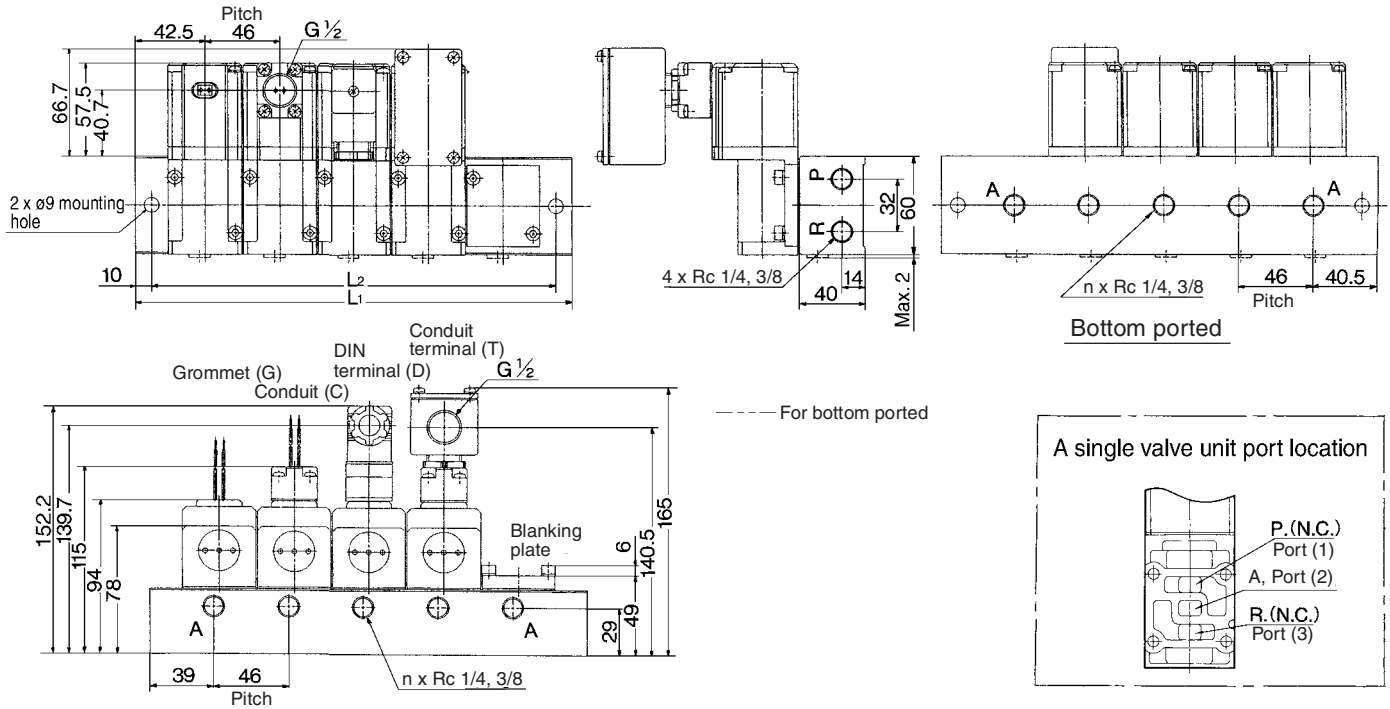

n: Stations

Symbol \ n	2	3	4	5	6	7	8	9	10
L1	131	177	223	269	315	361	407	453	499
L2	111	157	203	249	295	341	387	433	479

Formula: $L1 = 46n + 39$, $L2 = 46n + 19$



Series VT325 Specific Product Precautions

Be sure to read before handling. Refer to front matters 58 and 59 for Safety Instructions and pages 3 to 7 for 3/4/5 Port Solenoid Valve Precautions.

⚠ Caution

- The bottom of the solenoid valve has a breather hole for the main valve. Take proper measures to prevent this hole from being blocked as this will lead to a malfunction.
- Ordinarily, when the solenoid valve is mounted on a metal surface, it can breathe through the breather hole, via the breather groove. However, in particular, if the surface to be mounted is made of the rubber, the rubber could deform and block the hole.

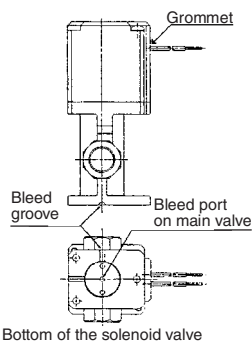

- Make sure that dust and/or other foreign materials do not enter the valve from the unused port (e.g. exhaust port). The grommet portion contains a breather hole for the core. Take proper measures to prevent dust or foreign matter from accumulating in this area.

Electrical Connection

For wiring to DIN terminal, connect the positive (+) polar side with connector terminal no. 1 and the negative (-) side with connector terminal no. 2 when the rated voltage is DC type.

How to Calculate the Flow Rate

For obtaining the flow rate, refer to front matters 44 to 47.

How to Wire DIN Terminal

1. Disassembly

- After loosening the thread (1), then if the cover (4) is pulled in the direction of the thread, the connector will be removed from the body of equipment (solenoid, etc.).
- Pull the screw (1), and then remove gasket (2a) or (2b).
- On the bottom part of the terminal block (3), there's a cut-off part (indication of an arrow) (3a). If a small flat head screwdriver is inserted between the opening in the bottom, terminal block (3) will be removed from the cover (4). (Refer to the figure below.)
- Remove the cable gland (5) and plain washer (6) and rubber seal (7).

2. Wiring

- Pass them through the cable (8) in the order of cable ground (5), washer (6), rubber seal (7), and then insert into the housing (4).
- Dimensions of the cable (8) are the figure as below. Skin the cable and crimp the crimped terminal (9) to the edges.
- Remove the screw with washer (3e) from the bracket (3e). (Loosen in the case of Y shape type terminal.) As shown in the below figure, mount a crimped terminal (9), and then again tighten the screw (3e).

Note) Tighten within the tightening torque of 0.5 N-m \pm 15%.
Note: a It is possible to wire even in the state of bare wire. In that case, loosen the screw with washer (3e) and place a lead wire into the bracket (3d), and then tighten it once again.

b The maximum size for the round terminal (9) is 1.25 mm²—3.5 and for the Y terminal is 1.25 mm²—4.

c Cable (8) external: ϕ 6 to ϕ 12

Note) For the one with the external dimension ranged between ϕ 9 to ϕ 12 remove the inside parts of the rubber seal (7) before using.

3. Assembly

- Terminal box (3) connected with housing (4) should be reinstated. (Push it down until you hear the click sound.)
 - Putting rubber seal (7), plain washer (6), in this order into the cable introducing slit on the housing (4), then further tighten the cable gland (5) securely.
 - By inserting gasket (2a) or (2b) between the bottom part of the terminal box (3) and a plug on an equipment, screw in (1) on top of the housing (4) and tighten it.
- Note) Tighten within the tightening torque of 0.5 N-m \pm 20%.
Note: The orientation of a connector can be changed arbitrarily, depending on the combination of a housing (4) and a terminal box (3).

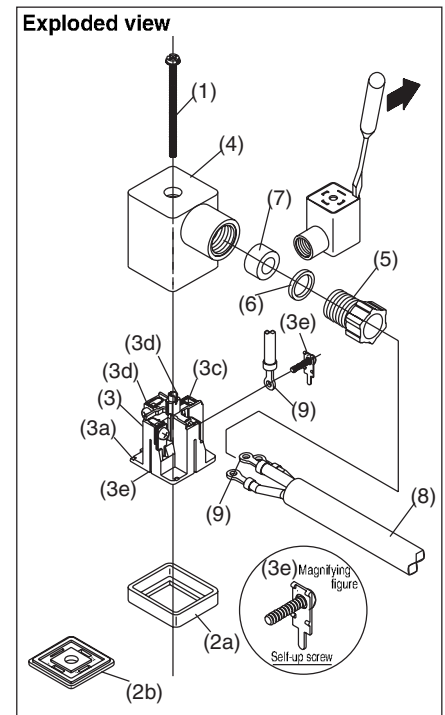

Connector for DIN Terminal

Description	Part no.
DIN connector	GDM2C